

**INOX BY  
NATURE: A  
DIALOGUE  
BETWEEN  
LIGHT  
MATERIALS**

**STRAL**

## Intro

Ogni cosa che puoi immaginare, la natura l'ha già creata, diceva Albert Einstein. STRAL da anni ha come obiettivo quello di produrre apparecchi d'illuminazione per esterni utilizzando esclusivamente l'acciaio inox, un materiale da cui non ci siamo mai allontanati perché ci consente di introdurci senza alcuna limitazione in tutti i contesti naturali che lo richiedono, anche i più aspri.

Ed è proprio dal ritmo e dalle regole della natura che questo nuovo catalogo trae profonda ispirazione. L'affidabilità del marchio si unisce ed evolve con la ricerca e la progettazione per generare uno stile rinnovato, unico e prezioso. Know-how e innovazione danno vita a una forte identità. I prodotti storici e intramontabili sono accompagnati da linee nuove, studiate e calibrate. L'identità dualista del marchio vede coesistere l'indefinito dato dalla luce, così poetica e impalpabile, modellata dal definito degli involucri in cui è avvolta, traducendo questo connubio in una collezione di apparecchi d'illuminazione equilibrati e progettati per essere altamente adatti ai contesti in cui si impegnano a stare. Come due elementi complementari, non c'è predominanza di uno sull'altro, le forme sono armonizzate e i materiali scelti sono pensati per consentire ai prodotti di vestirsi di ciò che li circonda.

## A. Zambelli

La genesi progettuale porta la firma di Alessandro Zambelli, che in questo percorso di rinnovamento del brand ha scelto di concentrare l'attenzione su nuovi punti focali.

«La mia visione del design pone in dialogo il presente con il passato e quello che esso può suggerire per creare il futuro: ogni nuovo progetto nasce da un antenato, da un'esigenza trascorsa da cui si percepisce la necessità di rispondere a una nuova.

Partendo da questo presupposto, abbiamo lavorato con l'intento di reinterpretare la percezione di un materiale no-

bile quale l'acciaio inox. Dare nuova linfa cromatica e tattile, pensando ad installazioni sempre più eterogenee per i prodotti Stral. Attenzione particolare è stata rivolta ai contesti storici e a tutti quei luoghi dove la presenza di materiali naturali richiede coerenza stilistica, garantendo tutte le peculiarità di resistenza e durata proprie dell'acciaio inox.

Un gioco di contrasti volto al continuo dialogo tra razionalità formale e libertà espressiva. L'acciaio inox si veste così di una livrea che dialoga con l'ambiente circostante. Ogni oggetto è stato pensato per assimilare e assumere le cromie del contesto in cui verrà installato, mediante un meticoloso lavoro di ricerca delle finiture e texture superficiali.

La purezza delle geometrie è parsa la linea più efficace per creare un fil rouge con l'essenza dell'acciaio inox. Tecnicamente l'azione progettuale si è soffermata sulla filiera produttiva, ricercando il massimo potenziale delle tecnologie di ultima generazione. Presupposto questo fondamentale per garantire un prodotto di qualità elevata, con un alto grado di finitura e dettaglio. Il valore della componente illuminotecnica è il frutto dell'esperienza Palazzolica che da sempre dimostra grande attenzione nello sviluppo di corpi lampada performanti e innovativi.»

EN

Everything you can imagine, nature has already created it, said Albert Einstein. For years STRAL's goal has been to produce outdoor lighting fixtures using exclusively stainless steel, a material we have never strayed from because it allows us to introduce ourselves without any limitation into all natural contexts that require it, even the most harsh.

And it is precisely from the rhythm and rules of nature that this new catalogue takes deep inspiration. The reliability of the brand joins and evolves with research and design to generate a renewed, unique, and precious style. Know-how and innovation create together a strong identity. The historic and timeless products are accompanied by the studied and calibrated design of the new lines. The dual identity of the brand sees the coexistence of the indefinite given by the light, so poetic and impalpable, shaped by the definition of the case in which it is wrapped, translating this union into a collection of balanced lighting fixtures designed to be highly suitable for contexts in which they commit themselves to be. As two complementary elements, there is no predominance of one over the other, the shapes are harmonised and the materials chosen are designed to allow the products to dress up with their surroundings.

The design genesis bears the signature of Alessandro Zambelli, who in this brand renewal journey, has chosen to focus attention on new key points.

« My design vision places the present in dialogue with the past and what it can suggest, to create the future: every new project is born from an ancestor, from a past need which gives us the feeling of responding to a new one.

Starting from this premise, we worked with the intention of reinterpreting the perception of a noble material such as stainless steel.

Giving new chromatic and tactile lymph, thinking of increasingly heterogeneous installations for Stral products. Particular attention was paid to historical contexts and to all those places where the presence of natural materials requires stylistic consistency, guaranteeing all the peculiarities of resistance and durability of stainless steel.

A game of contrasts aimed at the continuous dialogue between formal rationality and expressive freedom. Stainless steel thus is dressed on a livery that dialogues with the surrounding environment. Each object has been designed to assimilate and take on the colours of the context in which it will

be installed, through meticulous research of surface finishes and textures.

The purity of the geometries seemed to be the most effective line to create a common thread with stainless steel's essence. Technically, the design action has focused on the production chain, seeking the maximum potential of the latest generation technologies. This is a fundamental prerequisite to guarantee a high-quality product, with a high degree of finish and detail. The value of the lighting component is the result of Palazzoli's experience which has shown, over the years, great attention in the development of performing and innovative lamp bodies. »

FR

Tout ce que vous pouvez imaginer, la nature l'a déjà créé, disait Albert Einstein. STRAL, depuis plusieurs années, s'efforce à produire des luminaires d'extérieur exclusivement en acier inoxydable, un matériau que nous utilisons depuis toujours en raison de son utilisation sans aucune limitation dans tout environnement, même ceux les plus rudes.

Ce nouveau catalogue naît justement du rythme et des règles de la nature. La fiabilité de la marque est renforcée et évolue grâce à la recherche et au design. Le but est de créer un style renouvelé, unique et élégant. Le savoir-faire et l'innovation s'unissent pour donner une identité forte. Les produits historiques et intemporels sont accompagnés de nouvelles lignes, étudiées et calibrées. L'identité dualiste de la marque permet la coexistence de l'indéfini donné par la lumière, si poétique et impalpable, façonnée par la précision des revêtements qui l'entourent. Cette union se traduit en une collection de luminaires équilibrés et conçus pour s'adapter à n'importe quel environnement. En tant que deux éléments complémentaires, il n'y a pas de prédominance de l'un sur l'autre. Les formes s'harmonisent et les matériaux choisis sont conçus pour permettre aux produits de s'imprégner de leur environnement.

C'est Alessandro Zambelli qui signe la genèse du design. Dans un souci de renouvellement de la marque, il a choisi d'attirer l'attention sur de nouveaux points focaux.

« Ma vision du design permet au présent de dialoguer avec le passé tandis que ce dernier lui donne des suggestions pour créer le futur : chaque nouveau projet naît d'un ancêtre, d'un besoin du passé qui nous pousse à répondre à un nouveau.

C'est à partir de cette base que nous avons

travaillée et qui nous a permis de réinterpréter la perception d'un matériau noble comme l'inox. Donner une nouvelle lympe chromatique et tactile, en pensant à des installations de plus en plus hétérogènes pour les produits Stral. Nous avons été particulièrement attentifs aux contextes historiques et à tous ces lieux où la présence de matériaux naturels exige une cohérence stylistique, garantissant toutes les particularités de résistance et de durabilité de l'acier inoxydable.

Un jeu de contrastes qui permet un dialogue continu entre rationalité formelle et liberté d'expression. L'inox présente un nouvel habillage qui lui offre la possibilité de dialoguer avec l'environnement qui l'entoure. Chaque objet a été conçu pour assimiler et prendre les couleurs du contexte où il sera installé, grâce à une recherche minutieuse des finitions et des textures des surfaces.

La pureté des géométries s'est avérée la ligne la plus efficace pour créer un fil conducteur avec l'essence de l'inox. D'un point de vue technique, la conception s'est concentrée sur la chaîne de production, recherchant le potentiel maximum des technologies de dernière génération. Cette condition préalable est essentielle au moment de garantir un produit de haute qualité, avec un haut degré de finition et de détail. La valeur du composant d'éclairage est le résultat de l'expérience de Palazzoli qui depuis toujours porte une grande attention dans le développement de corps de lampe performants et innovants. »

DE

Alles, was man sich vorstellen kann, hat die Natur schon geschaffen, sagte Albert Einstein. Seit Jahren verfolgt STRAL das Ziel, Außenleuchten ausschließlich aus Edelstahl herzustellen, einem Material, von dem wir nie abgewichen sind, weil es uns ermöglicht, uns uneingeschränkt in alle natürlichen Kontexte einzufügen, die dies erfordern, auch in die härteren.

Und genau aus dem Rhythmus und den Regeln der Natur schöpft dieser neue Katalog tiefe Inspiration. Die Zuverlässigkeit der Marke verbindet und entwickelt sich mit Forschung und Design, um einen erneuerten, einzigartigen und kostbaren Stil zu schaffen. Know-how und Innovation schaffen eine starke Identität. Die historischen und zeitlosen Produkte werden von neuen, erforschten und kalibrierten Linien begleitet. Die dualistische Identität der Marke sieht die Unbestimmtheit des Lichts nebeneinander bestehend, so poetisch und ungreifbar, geprägt von der Definition der Gehäuse, in

die es eingehüllt ist, und übersetzt diese Verbindung in eine Kollektion ausgewogener Beleuchtungskörper, die sich hervorragend in ihren Kontext integrieren lassen. Als zwei sich ergänzende Elemente, in denen keines überwiegt, die Formen sind aufeinander abgestimmt und die Materialwahl so konzipiert, dass sich die Produkte an ihre Umgebung anpassen.

Die Gene des Designs trägt die Handschrift von Alessandro Zambelli, der auf diesem Weg der Erneuerung der Marke seinen Fokus auf neue Schwerpunkte gesetzt hat.

« Meine Vision von Design setzt die Gegenwart in Dialog mit der Vergangenheit und was sie zur Gestaltung der Zukunft vorschlagen kann: Jedes neue Projekt wird aus einem vorigen geboren, aus einem vergangenen Bedürfnis, das uns das Gefühl gibt, auf ein neues zu reagieren.

Ausgehend von diesem Gesichtspunkt haben wir mit der Absicht gearbeitet, die Wahrnehmung eines edlen Materials wie Edelstahl neu zu interpretieren. Neues chromatische und taktiles Leben verleihen, und dabei immer an die zusammenstellbaren Installationen für Stral-Produkte denken. Besonderes Augenmerk wurde auf historische Kontexte und all jene Orte gelegt, an denen das Vorhandensein natürlicher Materialien eine stilistische Beständigkeit erfordert, und dabei alle Besonderheiten der Widerstandsfähigkeit und Haltbarkeit von Edelstahl garantiert.

Ein Spiel der Kontraste, das auf den kontinuierlichen Dialog zwischen formaler Rationalität und expressiver Freiheit abzielt. Dadurch erhält Edelstahl eine Optik, die mit der Umgebung in Dialog tritt. Jedes Objekt wurde so entworfen, dass es die Farben des Kontexts, in dem es installiert wird, durch eine sorgfältige Untersuchung von Oberflächen und Texturen aufgreift und annimmt.

Die Reinheit der Geometrien schien die effektivste Linie zu sein, um einen gemeinsamen Faden mit der Essenz des Edelstahls zu schaffen. Technisch konzentrierte sich das Design auf die Produktionskette und erforschte das maximale Potenzial der Technologien der neuesten Generation. Dies ist unerlässlich, um ein qualitativ hochwertiges Produkt mit einem hohen Grad an Verarbeitung und Detail zu garantieren. Der Wert der Beleuchtungskomponente ist das Ergebnis der Erfahrung von Palazzoli, die immer große Aufmerksamkeit bei der Entwicklung von leistungsstarken und innovativen Lampenkörpern gezeigt hat. »



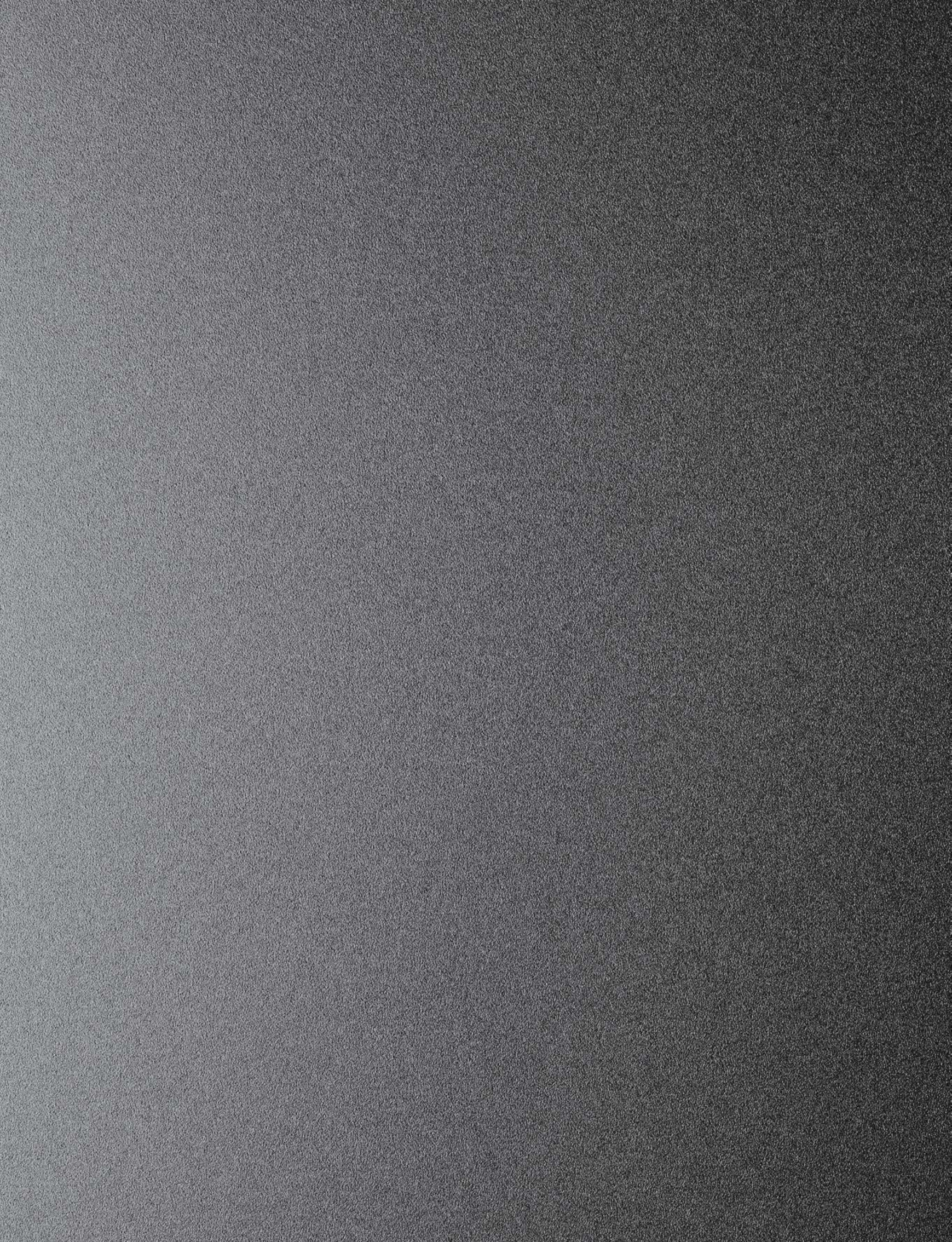



In ground recessed

OLY		BASE	
N110	19	V02	31
N180	21	V03	33
N240	23	H02	35
		H03	37

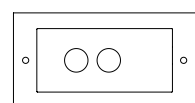
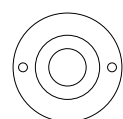

Wall recessed

OTTAGONO		KANDOVAN	
N80	45	H130	51
		H270	53

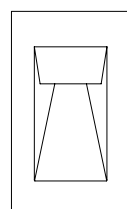
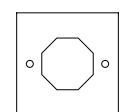

In ground / Wall recessed

STARLIGHT		GAME	
N100	59	N01/ N02	65
		N04	67
		N180	69

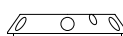

Wall mounted

77

LOCH		DYKE		SILL	
M90	79	M01	99	M03	119
M120	81	M02	101	B03	121
M180	83	M03	103		
B90	85	B01	105		
B120	87	B02	107		
B180	89	B03	109		

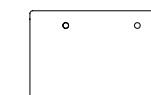
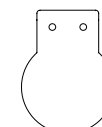

Floodlights

125

FOCAL		BENTH		DYKE ROTO	
D50	127	T100	137	M01	143
D70	129			M02	145
				M03	147

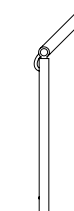
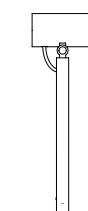

DYKE FLEX		HOKU	
M01	153	D50	163
M02	155	D70	165
M03	157		

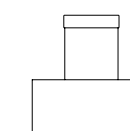
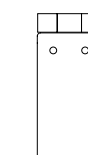

# Bollards

171

KРАН		DAN		VOLK	
M01	173	M90	189	H50	197
M02	175	M120	191		
M03	177				

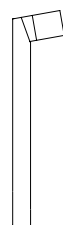
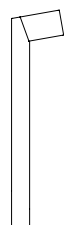

CAUSEWAY	
M01	203
M02	205
M03	207



# Modular systems

211

DIAL	
H2500 / H3000	213

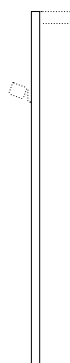

# Pole-top systems

219

MOON		SHELFIE	
N200	221	T700	231
N270	223		

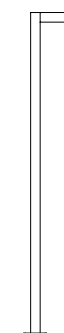
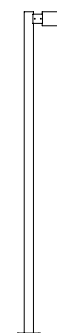

# Accessories

237





---

#### About

OLY è da sempre uno dei prodotti di riferimento della collezione Stral. Negli anni si sono susseguite al suo interno le varie sorgenti luminose del momento e oggi lo presentiamo così, ancora più curato nei dettagli, ancora più affidabile e performante, per continuare ad illuminare in tutta sicurezza gli esterni tra facciate e spazi architettonici.

# N

# 110



Inox Natural



Inox Graphite



Inox Bronze



# N

# 180



Inox Natural



Inox Graphite



Inox Bronze



# N



Inox Natural



Inox Graphite



Inox Bronze

# 240



EN Ring and lamp body in AISI 316L stainless steel, including the part embedded in the ground. 21°, 45° and 65° optics at 2700K, 3000K and 4000K and with GU10 lampholder for OLY N110. Stainless steel fixing screws with color matched to the finish. Installation in the ground and/or on the floor through raised casing, 8 mm thick extra-clear tempered glass. Integrated power supply. HCT surface finish available in three variants.

ITA Anello e corpo lampada in acciaio inox AISI 316L, compresa la parte incassata nel terreno. Ottiche da 21°, 45° e 65° da 2700K, 3000K e 4000K e con attacco GU10 per OLY N110. Viti di fissaggio in acciaio inox con colorazione abbinata alla finitura. Installazione nel terreno e/o a pavimento tramite controcassa a battuta. Vetro temperato extra-chiaro di spessore 8 mm. Alimentatore integrato. Finitura superficiale HCT disponibile in tre varianti.

FR Bague et corps de lampe en acier inox AISI 316L, y compris la partie encastrée dans le sol. Optiques de 21°, 45° et 65° à 2700K, 3000K et 4000K et avec fixation GU10 pour OLY N110. Vis de fixation en acier inox. Couleur assortie à la finition. Installation dans le sol et/ou au sol au moyen d'une double caisse en butée. Verre trempé extra-clair de 8 mm d'épaisseur. Alimentateur intégré. Finition de surface HCT disponible en trois variantes.

DE Ring und Leuchtenkörper aus Edelstahl AISI 316L, einschließlich des im Boden eingelassenen Teils. Optiken von 21°, 45° und 65° von 2700K, 3000K und 4000K und mit GU10-Anschluss für OLY N110. Befestigungsschrauben aus Edelstahl, farblich auf die Endbearbeitung abgestimmt. Installation im Boden und/oder auf dem Boden mittels eines Anschlaggehäuses. Extra klares gehärtetes Glas 8 mm dick. Integriertes Netzteil. HCT-Oberflächenbearbeitung in drei Ausführungen erhältlich.

OLY N110

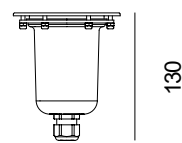

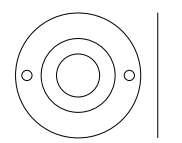

130

110



110

110

Color			Emission
2700 K 543 lm	3000 K 550 lm	4000 K 613 lm	
Power 5 W	 Codes Technical details		
IP66   IP67   IK09 		Accessories p. 237	

Color		Emission
GU10 220 V	 Codes Technical details	

OLY N180

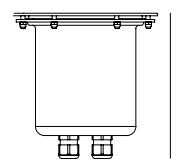

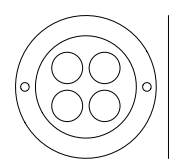

170

173



173

173

Color			Emission
2700 K 1522 lm	3000 K 1540 lm	4000 K 1717 lm	
Power 12 W	 Codes Technical details		
IP66   IP67   IK09 		Accessories p. 237	

Color			Emission
2700 K 2174 lm	3000 K 2200 lm	4000 K 2453 lm	
Power 18 W	 Codes Technical details		

OLY N240

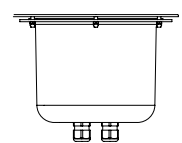

180

235

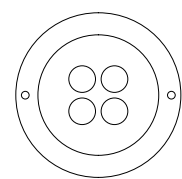

235

235

Color			Emission
2700 K 2964 lm	3000 K 3000 lm	4000 K 3345 lm	
Power 24 W	 Codes Technical details		
IP66   IP67   IK09 		Accessories p. 237	



Translations

EN OLY has always been one of the reference products of the Stral collection. Over the years, the various light sources of the moment have followed one another inside it, and today we present it in this way with even more attention to detail, even more reliable performance, to continue to safely illuminate the outdoors between facades and architectural spaces.

FR OLY a toujours été l'un des produits de référence de la collection Stral. Au fil des ans, les différentes sources lumineuses du moment se sont succédées et aujourd'hui nous la présentons ainsi : des détails encore plus soignés pour un produit encore plus fiable et performant, dans le but de continuer à éclairer en toute sécurité les extérieurs entre façades et espaces architecturaux.

DE OLY ist seit jeher eines der Referenzprodukte der Stral-Kollektion. Im Laufe der Jahre folgten die verschiedenen Lichtquellen der Gegenwart und heute präsentieren wir es auf diese Weise, noch mehr Liebe zum Detail, noch zuverlässiger und leistungsfähiger, um den Außenbereich zwischen Fassaden und architektonischen Räumen weiterhin sicher zu beleuchten.



# BASE



---

## About

BASE è concepito per essere un vero e proprio punto di riferimento, un emblema di sicurezza laddove ci sia l'esigenza di avere un'illuminazione affidabile e sapiente. Come nel baseball, la base è il punto focale del gioco, così anche BASE è l'elemento che si installa nel terreno e aiuta a valorizzare con la sua luce la scena in cui viene inserito.

# V

# 02



Inox Natural



Inox Graphite



Inox Bronze





# V

# 03



Inox Natural



Inox Graphite



Inox Bronze

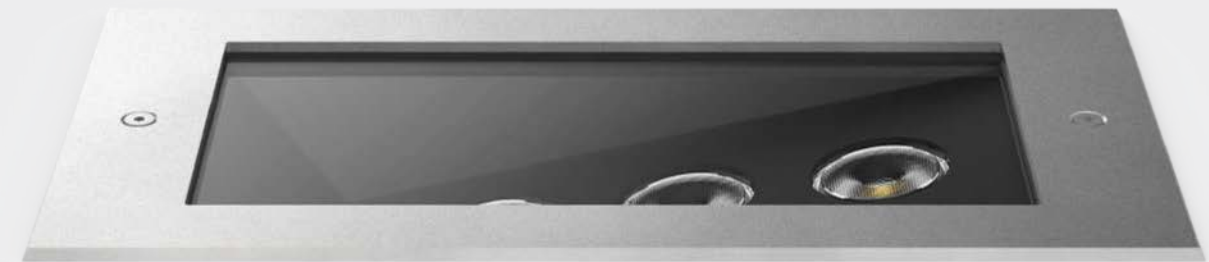



Inox Natural



Inox Graphite



Inox Bronze





Inox Natural



Inox Graphite



Inox Bronze



EN Frame and lamp body in stainless steel, including the part recessed in the ground. Stainless steel fixing screws with color matched to the finish. Horizontal or vertical asymmetrical reflector. Optics from 21°, 45° and 65° at 2700K, 3000K and 4000K. Installation in the ground and/or on the floor through polyethylene outer casing. 8mm extra-clear tempered glass. Integrated power supply. HCT surface finish available in three variants.



ITA Cornice e corpo lampada in acciaio inox, compresa la parte incassata nel terreno. Viti di fissaggio in acciaio inox con colorazione abbinata alla finitura. Riflettore asimmetrico orizzontale o verticale. Ottiche da 21°, 45° e 65° a 2700K, 3000K e 4000K. Installazione nel terreno e/o a pavimento tramite controcassa in polietilene. Vetro temperato extra-chiaro da 8 mm. Alimentatore integrato. Finitura superficiale HCT disponibile in tre varianti.

FR Cadre et corps de lampe en acier inox, y compris la partie encastrée dans le sol. Vis de fixation en acier inox. Couleur assortie à la finition. Réflecteur asymétrique horizontal ou vertical. Optiques de 21°, 45° et 65° à 2700K, 3000K et 4000K. Installation dans le sol et/ou au sol au moyen d'une double caisse en polyéthylène. Verre trempé extra-clair de 8 mm. Alimentation intégrée. Finition de surface HCT disponible en trois variantes.

DE Rahmen und Leuchtenkörper aus Edelstahl, einschließlich des im Boden eingelassenen Teils. Befestigungsschrauben aus Edelstahl, farblich auf die Endbearbeitung abgestimmt. Horizontaler oder vertikaler asymmetrischer Reflektor. Optiken von 21°, 45° und 65° bis 2700K, 3000K und 4000K. Installation im Boden und/oder auf dem Boden mittels eines Gehäuses aus Polyethylen. 8 mm extra klares gehärtetes Glas. Integriertes Netzteil. HCT-Oberflächenbearbeitung in drei Ausführungen erhältlich.

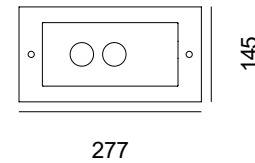
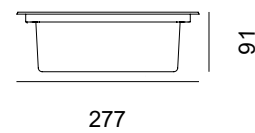

#### BASE V02



Color			Emission
2700 K	3000 K	4000 K	
1482 lm	1500 lm	1673 lm	21°
Power 12 W			45°
 Codes Technical details			65°
IP66	IP67	IK08	 Accessories p. 238

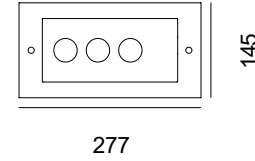
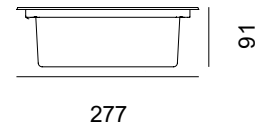

#### BASE V03



Color			Emission
2700 K	3000 K	4000 K	
2223 lm	2250 lm	2509 lm	21°
Power 18 W			45°
 Codes Technical details			65°
IP66	IP67	IK08	 Accessories p. 238

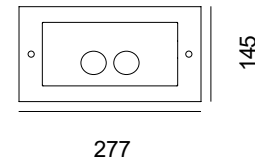
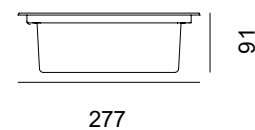

#### BASE H02

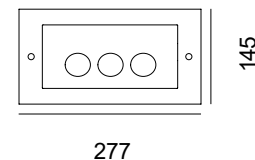
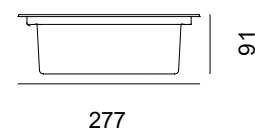

Color			Emission
2700 K	3000 K	4000 K	
1482 lm	1500 lm	1673 lm	21°
Power 12 W			45°
 Codes Technical details			65°
IP66	IP67	IK08	 Accessories p. 238

#### BASE H03



Color			Emission
2700 K	3000 K	4000 K	
2223 lm	2250 lm	2509 lm	21°
Power 18 W			45°
 Codes Technical details			65°
IP66	IP67	IK08	 Accessories p. 238



#### Translations

EN BASE is designed to be a real landmark, an emblem of safety where reliable and professional lighting is needed. As in baseball, the base is the focal point of the game, so BASEtoo is the element that if installed in the ground helps, with its light, to enhance the scene in which it is inserted.

FR BASE est conçu comme un véritable point de référence, un emblème de sécurité là où un éclairage fiable et habile est requis. Comme dans le baseball, la base est le point central du jeu. BASE est donc l'élément qui est installé dans le sol et qui contribue à travers sa lumière à valoriser le site où il est inséré.

DE BASE ist als echter Bezugspunkt ausgelegt, ein Symbol für Sicherheit, wo zuverlässige und fachmännische Beleuchtung benötigt wird. Wie beim Baseball wo die Base der Mittelpunkt des Spiels ist, so ist auch BASE das Element, das in den Boden eingebaut wird und hilft, die Szene, in die es eingefügt wird, mit seinem Licht zu verstärken.



# OTTAGONO



---

## About

OTTAGONO, è nato per rendere gli ambienti un luogo emozionante e di comunicazione. Il design si ispira ai concetti di movimento, trasformazione, flessibilità. Un concept d'illuminazione unico nel suo genere grazie al sistema di maschere intercambiabili in grado di scolpire l'ombra. Lo ritroviamo con la sua unicità concettuale, con migliorate proporzioni e performance illuminotecniche.

# N

# 80



Inox Natural



Inox Graphite



Inox Bronze



EN Frame is made entirely of AISI 316L stainless steel with HCT surface finish, available in three variants. Screws in stainless steel too, are colour matched to the finish. The octagonal masks inside the lamp body house the filters for optics with beam spreads of 20°, 30° and 45° with colour temperatures at 2700K, 3000K and 4000K.

A polypropylene casing is used for wall installation. Remote power supply.

ITA Cornice realizzata totalmente in acciaio inox AISI 316L con finitura superficiale HCT disponibile in tre varianti. Viti anch'esse in acciaio inox con colorazione abbinata alla finitura. Le maschere ottagonali all'interno del corpo lampada ospitano i filtri per ottiche con aperture da 20°, 30° e 45° con temperature colore da 2700K, 3000K e 4000K. Controcassa in polipropilene per installazione a parete. Alimentatore remoto.

FR Cadre réalisé entièrement en acier inox AISI 316L avec finition de surface HCT disponible en trois variantes. Vis également en acier inox. Couleur assortie à la finition. Les masques octogonaux à l'intérieur du corps de la lampe abritent les filtres pour optiques avec ouvertures de 20°, 30° et 45° et avec des températures de couleur de 2700K, 3000K et 4000K. Double caisse en polypropylène pour installation murale. Alimentation à distance.

DE Rahmen vollständig hergestellt aus Edelstahl AISI 316L mit HCT-Oberflächenbearbeitung in drei Ausführungen erhältlich. Schrauben auch aus Edelstahl, farblich auf die Endbearbeitung abgestimmt. Die achteckigen Masken im Inneren des Lampengehäuses enthalten die Filter für Optiken mit Öffnungen von 20°, 30° und 45° mit Farbtemperaturen von 2700K, 3000K und 4000K. Gehäuse aus Polypropylen für die Wandmontage. Fernstromversorgung.

## OTTAGONO N80

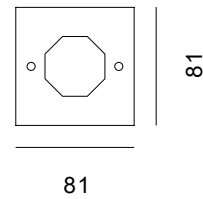
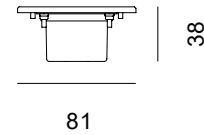

Colour	Emission	
2700 K 543 lm	3000 K 550 lm	4000 K 613 lm
Power 5 W	Codes Technical details	
IP65	IK07	Driver & accessories p. 238

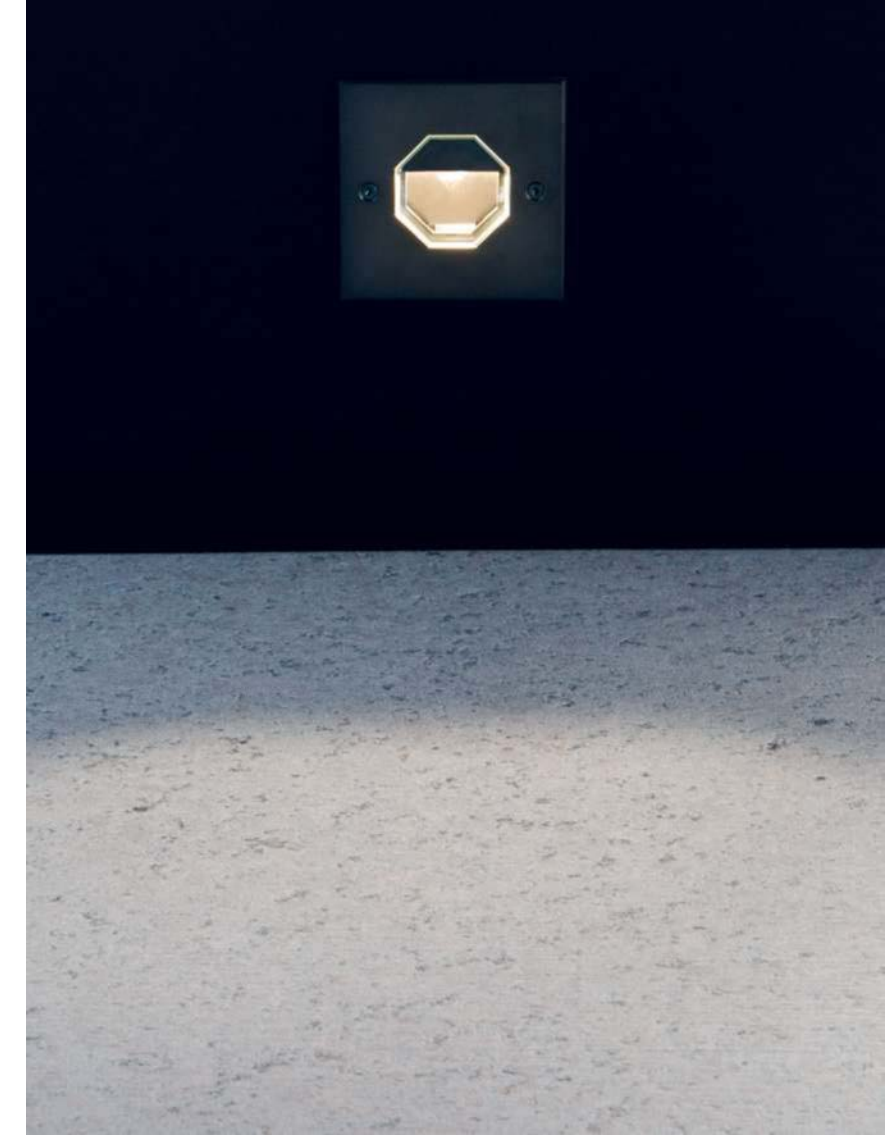

### Translations

EN OTTAGONO, has been created to make environments an exciting and communicative place. The design is inspired by the concepts of movement, transformation, flexibility. A unique lighting concept of its kind thanks to the system of interchangeable masks capable of sculpting the shadow. We find it with its conceptual uniqueness, with improved proportions and lighting performance.

FR OTTAGONO a été créé pour que les environnements ou il est intégré deviennent des lieux de communication. Le design s'inspire des concepts de mouvement, de transformation et de flexibilité. Un concept d'éclairage unique en son genre grâce au système de masques interchangeables capables de sculpter l'ombre. Nous le retrouvons avec son unicité conceptuelle, avec des proportions et des performances d'éclairage améliorées.

DE OTTAGONO entstand, um Umgebungen zu einem spannenden und kommunikativen Ort zu machen. Das Design ist inspiriert von den Konzepten der Bewegung, Transformation, Flexibilität. Ein einzigartiges Beleuchtungskonzept seiner Art dank des Systems austauschbarer Masken, die den Schatten formen können. Wir entdecken es wieder mit seiner konzeptuellen Einzigartigkeit, mit verbesserten Proportionen und Lichtleistung.





Product

# KANDOVAN

---

## About

Alcune forme, in particolari contesti costruttivi sono funzionali più che estetiche. A KANDOVAN, nell'Azerbaijan orientale, le piccole finestre e le porte delle abitazioni scavate nella roccia, sono sempre a favore del sole, in modo da scaldare l'ambiente durante l'inverno. Ispirata dagli elementi sulle pareti di queste strutture, nasce la nuova linea d'illuminazione radente.



Inox Natural



Inox Graphite

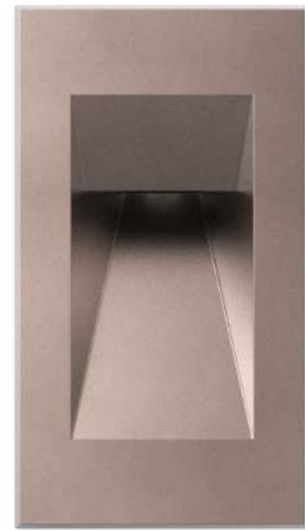

Inox Bronze



# H

# 270



Inox Natural



Inox Graphite



Inox Bronze



EN Frame and body made of AISI 316L stainless steel. Optical reflector in AISI 316L stainless steel for grazing lighting. Applied tempered shielding glass 4 mm thick. Wide and symmetrical optics at 2700K, 3000K and 4000K. Stainless steel fixing screws with colour matched to the finish. Wall installation with polyethylene outer casing. Integrated power supply. HCT surface finish available in three variants.

ITA Cornice e corpo realizzati in acciaio inox AISI 316L. Riflettore ottico in acciaio inox AISI 316L per l'illuminazione radente. Vetro temprato di schermatura applicato di spessore 4 mm. Ottiche wide e simmetrica da 2700K, 3000K e 4000K. Viti di fissaggio in acciaio inox con colorazione abbinata alla finitura. Installazione a parete con contro-cassa in polietilene. Alimentatore integrato. Finitura superficiale HCT disponibile in tre varianti.

FR Cadre et corps en acier inox AISI 316L. Réflecteur optique en acier inox AISI 316L pour éclairage rasant. Verre trempé de protection appliqué de 4 mm d'épaisseur. Optiques larges et symétriques de 2700K, 3000K et 4000K. Vis de fixation en acier inox. Couleur assortie à la finition. Installation murale avec double caisse en polyéthylène. Alimentation intégrée. Finition de surface HCT disponible en trois variantes.

DE Rahmen und Gehäuse aus Edelstahl AISI 316L. Optischer Reflektor aus Edelstahl AISI 316L für Streiflicht. Angewandtes gehärtetes Abschirmglas 4 mm dick. Optiken wide und symmetrisch von 2700K, 3000K und 4000K. Befestigungsschrauben aus Edelstahl, farblich auf die Endbearbeitung abgestimmt. Wandmontage mit Gehäuse aus Polyethylen. Integriertes Netzteil. HCT-Oberflächenbearbeitung in drei Ausführungen erhältlich.

#### KANDOVAN H130

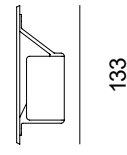

45

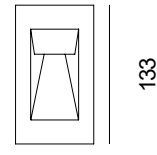

75

Colour		Emission
2700 K 186 lm	3000 K 197 lm	4000 K 212 lm
		Wide

Power 3W



Codes Technical details

IP65 IK08 Accessories p. 238

#### KANDOVAN H270



91

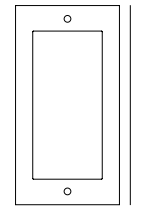

145

Colour		Emission
2700 K 982 lm	3000 K 987 lm	4000 K 1047 lm
		Symmetrical

Power 10 W



Codes Technical details

IP65 IK08 Accessories p. 238



#### Translations

EN Some shapes, in particular constructional contexts, are functional rather than aesthetic. In KANDOVAN, in eastern Azerbaijan, the small windows and doors of the houses carved in the rock always favour the sun, to warm the environment during the winter. Inspired by the elements on the walls of these structures, is born this new grazing lighting line.

FR Certaines formes, en particulier dans des contextes de construction, sont fonctionnelles plutôt qu'esthétiques. À KANDOVAN, dans l'est de l'Azerbaïdjan, les petites fenêtres et portes des maisons taillées dans la roche sont pensées pour laisser entrer le soleil, afin de réchauffer l'espace en hiver. Inspirée par les éléments sur les murs de ces structures, la nouvelle ligne d'éclairage rasant est née.

DE Einige Formen, insbesondere Konstruktionskontexte, sind eher funktional als ästhetisch. In KANDOVAN, im Osten Aserbaidschans, sind die kleinen Fenster und Türen der in den Fels gehauenen Häuser immer zur Sonne ausgerichtet, um die Umgebung im Winter zu erwärmen. Inspiriert von den Elementen an den Wänden dieser Bauwerke entsteht die neue Streiflichtlinie.



Product

# STARLIGHT

---

## About

STARLIGHT, per le sue dimensioni ridotte trova applicazione nei contesti dove è richiesta un'illuminazione discreta, ma scenografica. Sfizioso ed elegante, da anni illumina viali e camminamenti. Applicato sulle pareti ne disegna le superfici. Oggi ha mantenuto le sue caratteristiche fondamentali, ma brilla ancora di più.

# N



Inox Natural



Inox Graphite



Inox Bronze

# 100



EN Grazing light obtained thanks to the six windows with concentrated optics and colour temperatures of 2700K, 3000K and 4000K.

Made entirely in AISI 316L stainless steel, with HCT surface finishes available in three variants. Draining casing in polypropylene for wall and floor installation. Remote power supply to be housed in the outer casing.

ITA Luce radente ottenuta grazie alle sei aperture con ottiche concentranti con temperature colore da 2700K, 3000K e 4000K. Realizzato totalmente in acciaio inox AISI 316L con finitura superficiale HCT disponibile in tre varianti. Controcassa drenante in polipropilene per installazione a parete e pavimento. Alimentatore remoto da posizionare all'interno della controscassa.



FR Lumière rasante obtenue grâce aux six ouvertures avec optiques de concentration et avec des températures de couleur de 2700K, 3000K et 4000K. Réalisé entièrement en acier inox AISI 316L avec finition de surface HCT disponible en trois variantes. Double caisse drainante en polypropylène pour installation murale et au sol. Alimentation à distance à placer à l'intérieur de la double caisse.

DE Streiflicht dank der sechs Öffnungen mit konzentrierender Optik mit Farbtemperaturen von 2700K, 3000K und 4000K. Vollständig hergestellt aus Edelstahl AISI 316L mit HCT-Oberflächenbearbeitung in drei Ausführungen erhältlich. Ablaufgehäuse aus Polypropylen für die Wand- und Bodenmontage. Fernstromversorgung im Außengehäuse zu positionieren.

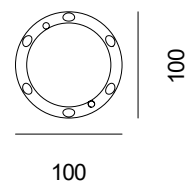
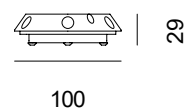
STARLIGHT N100



Colour			Emission
2700 K 1482 lm	3000 K 1500 lm	4000 K 1673 lm	360°
Power 5 W		 Codes Technical details	

IP66 IP67 IK10   Driver & accessories p. 238



Translations

EN STARLIGHT, due to its small size, finds application in contexts where discreet but scenographic lighting is required. Fanciful and elegant, it has been lighting up avenues and walkways for years. Applied to walls or floors, it draws the surfaces. Today it has kept its basic characteristics, but it shines even more.

FR STARLIGHT, en raison de sa petite taille, est idéale pour les contextes où un éclairage discret mais scénographique est requis. Original et élégant, il illumine les avenues et allées depuis des années. Appliqué sur les murs, il dessine les surfaces. Aujourd'hui, il a conservé ses caractéristiques de base, mais il brille encore plus.

DE STARLIGHT findet aufgrund seiner geringen Größe Anwendung in Kontexten, in denen diskrete, aber szenografische Beleuchtung erforderlich ist. Fantasievoll und elegant beleuchtet sie seit Jahren Alleen und Gehwege. Auf den Wänden aufgetragen, zeichnet es die Oberflächen. Bis heute hat es seine grundlegenden Eigenschaften behalten, aber mit noch mehr Glanz.

# GAME



---

## About

GAME, come suggerisce il nome, da anni è il prodotto della famiglia STRALin grado di ricreare giochi di luce per illuminare in modo scenografico ed efficace pareti e superfici, ma anche camminamenti e vialetti. Lo ritroviamo rinnovato in una veste ancora più accattivante e versatile per esprimere al meglio la fantasia progettuale.



# N

# 01 / 02



Inox Natural



Inox Graphite



Inox Bronze





Inox Natural



Inox Graphite



Inox Bronze



# N



Inox Natural



Inox Graphite



Inox Bronze

# 180



EN Grazing light thanks to single, double, quadruple, or single 180° openings. 10°, 30° and wide optics at 2700K, 3000K and 4000K. Made of AISI 316L stainless steel with HCT surface finish available in three variants. Stainless steel fixing screws, colour matched to the finish. Draining casing in polypropylene with counter ring in AISI 316L stainless steel for wall and floor installation. Remote power supply.

ITA Luce radente grazie alle aperture singola, doppia, quadrupla o singola da 180°. Ottiche da 10°, 30° e wide da 2700K, 3000K e 4000K. Realizzato in acciaio inox AISI 316L con finitura superficiale HCT disponibile in tre varianti. Viti di fissaggio in acciaio inox con colorazione abbinata alla finitura. Controcassa drenante in polipropilene con controanello in acciaio inox AISI 316L per installazione a parete e pavimento. Alimentatore remoto.

FR Lumière rasante grâce à des ouvertures simples, double, quadruple ou simple à 180°. Optiques de 10°, 30° à 2700K, 3000K et 4000K. En acier inox AISI 316L avec finition de surface HCT disponible en trois variantes. Vis de fixation en acier inox. Couleur assortie à la finition. Double caisse drainante en polypropylène avec contre-bague en acier inox AISI 316L pour installation murale et au sol. Alimentation à distance.

DE Streiflicht durch einzelne, doppelte, vierfache oder 180°-Einzel-Öffnungen. Optiken von 10°, 30° und wide von 2700K, 3000K und 4000K. Hergestellt aus Edelstahl AISI 316L mit HCT-Oberflächenbearbeitung in drei Ausführungen erhältlich. Befestigungsschrauben aus Edelstahl, farblich auf die Endbearbeitung abgestimmt. Ablaufgehäuse aus Polypropylen mit Gegenring aus Edelstahl AISI 316L für Wand- und Bodenmontage. Fernstromversorgung.

#### GAME N01

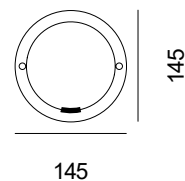
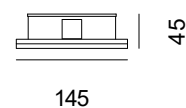

Colour		
2700 K 186 lm	3000 K 197 lm	4000 K 212 lm

Power  
3 W



Codes  
Technical details

Emission  
10°

30°

IP66 IP67 IK08 Driver & accessories p. 238

#### GAME N02

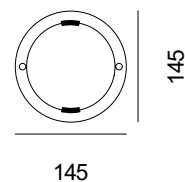
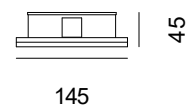

Colour		
2700 K 2 x 186 lm	3000 K 2 x 197 lm	4000 K 2 x 212 lm

Power  
2 x 3 W



Codes  
Technical details

Emission  
10° + 10°

30° + 30°

IP66 IP67 IK08 Driver & accessories p. 238

#### GAME N04

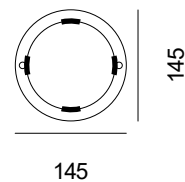
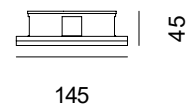

Colour		
2700 K 4 x 186 lm	3000 K 4 x 197 lm	4000 K 4 x 212 lm

Power  
4 x 3 W



Codes  
Technical details

Emission  
10°

30°

IP66 IP67 IK08 Driver & accessories p. 238

#### GAME N180

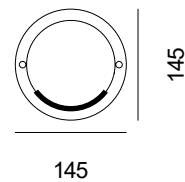
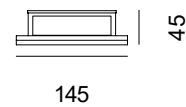

Colour		
2700 K 186 lm	3000 K 197 lm	4000 K 212 lm

Power  
3 W



Codes  
Technical details

Emission  
Wide

IP66 IP67 IK08 Driver & accessories p. 238



#### Translations

EN GAME, as the name suggests, has for years been the product of the STRAL family, able to recreate light games to illuminate walls and surfaces in a scenographic and effective way, but also walkways and paths. We find it renewed in an even more captivating and versatile way, to better express the design imagination.

FR GAME, comme son nom l'indique, est depuis des années le produit phare de la famille STRAL qui recrée des jeux de lumière pour éclairer les murs et les surfaces de manière scénographique et efficace, mais aussi les allées et les chemins. Il a été renouvelé d'une manière encore plus captivante et polyvalente pour mieux exprimer l'imaginaire véhiculé par le design.

DE GAME ist, wie der Name schon sagt, seit Jahren das Produkt der STRAL-Familie, das Lichtspiele nachbildet, um Wände und Flächen szenografisch und effektiv zu beleuchten, aber auch Gehwege und Wege. Wir haben es auf eine noch faszinierendere und vielseitigere Weise erneuert, um die Designvorstellung besser auszudrücken.





# LOCH



---

## About

Uno specchio d'acqua dove tutto ciò che lo circonda ci si riflette all'interno. È sempre ispirandosi alla natura e ai suoi fenomeni che nasce LOCH, sinuoso e compatto, concepito per illuminare le superfici delle pareti, e simultaneamente vestendosi della loro stessa materia grazie ai riflessi che questo oggetto porta al suo interno.

# M



Inox Natural



Inox Graphite

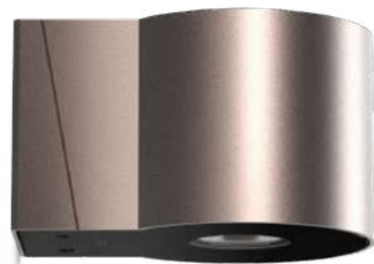

Inox Bronze

# 90





# M

# 120



Inox Natural



Inox Graphite



Inox Bronze



# M



Inox Natural



Inox Graphite



Inox Bronze

# 180



# B



Inox Natural



Inox Graphite



Inox Bronze

# 90



# B



Inox Natural



Inox Graphite



Inox Bronze

# 120



# B



Inox Natural



Inox Graphite



Inox Bronze

# 180



EN The spacer integrated with the lamp body makes the product compact. Made of AISI 316L stainless steel. Flush black silk-screened glass extra-clear tempered, 4mm thick. Available in single and bi-emission versions in three distinct diameters for different design needs. 21°, 45° and 65° optics with colour temperatures of 2700K, 3000K and 4000K. Integrated power supply. HCT surface finish available in three variants.

ITA Il distanziale integrato con il corpo lampada rende il prodotto compatto. Realizzato in acciaio inox AISI 316L. Vetro a filo serigrafato nero, temperato extra-chiaro di spessore 4 mm. Disponibile nelle versioni mono e bi-emissione in tre distinti diametri per le diverse esigenze progettuali. Ottiche da 21°, 45° e 65° con temperature colore da 2700K, 3000K e 4000K. Alimentatore integrato. Finitura superficiale HCT disponibile in tre varianti.

FR L'entretoise intégrée au corps de la lampe rend le produit compact. En acier inox AISI 316L. Verre affleurant sérigraphié noir, trempé extra-clair de 4 mm d'épaisseur. Disponible en versions mono et bi-émission en trois diamètres différents selon les exigences de conception. Optiques de 21°, 45° et 65° avec des températures de couleur de 2700K, 3000K et 4000K. Alimentation intégrée. Finition de surface HCT disponible en trois variantes.

DE Der im Leuchtenkörper integrierte Abstandhalter macht das Produkt kompakt. Hergestellt aus Edelstahl AISI 316L. Bündiges, extra klares gehärtetes schwarzes Siebdruckglas 4 mm dick. Erhältlich in den Versionen Einzelleuchte und Doppelleuchte in drei unterschiedlichen Durchmessern für unterschiedliche Designanforderungen. Optiken von 21°, 45° und 65° mit Farbtemperatur von 2700K, 3000K und 4000K. Integriertes Netzteil. HCT-Oberflächenbearbeitung in drei Ausführungen erhältlich.

#### LOCH M90

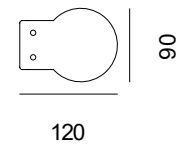
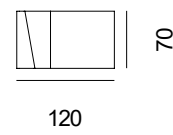

Colour			Emission
2700 K 543 lm	3000 K 550 lm	4000 K 613 lm	
Power 5 W			45°
Codes Technical details			65°
IP66		IK08	

#### LOCH M120

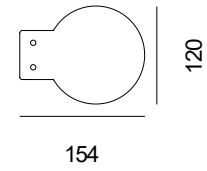
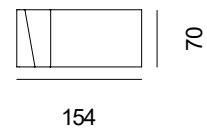

Colour			Emission
2700 K 741 lm	3000 K 750 lm	4000 K 836 lm	
Power 7 W			45°
Codes Technical details			65°
IP66		IK08	

#### LOCH M180

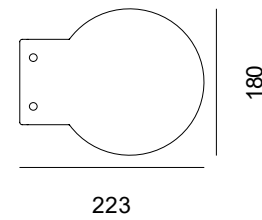
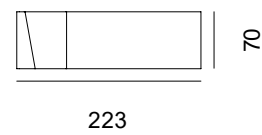

Colour			Emission
2700 K 2174 lm	3000 K 2200 lm	4000 K 2453 lm	
Power 18 W			45°
Codes Technical details			65°
IP66		IK08	

#### LOCH B90

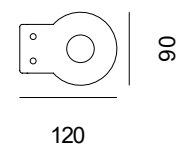
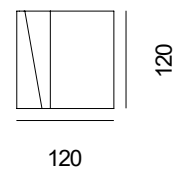

Colour			Emission
2700 K 2 x 543 lm	3000 K 2 x 550 lm	4000 K 2 x 613 lm	
Power 2 x 5 W			45° + 45°
Codes Technical details			65° + 65°
IP66		IK08	

#### LOCH B120

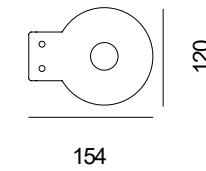
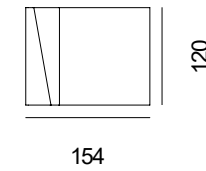

Colour			Emission
2700 K 2 x 741 lm	3000 K 2 x 750 lm	4000 K 2 x 836 lm	
Power 2 x 7 W			45° + 45°
Codes Technical details			65° + 65°
IP66		IK08	

#### LOCH B180

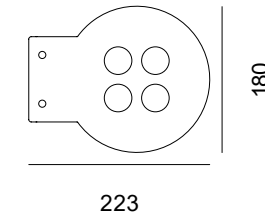
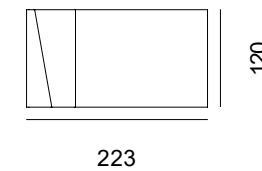

Colour			Emission
2700 K 2 x 2174 lm	3000 K 2 x 2200 lm	4000 K 2 x 2453 lm	
Power 2 x 18 W			45° + 45°
Codes Technical details			65° + 65°
IP66		IK08	

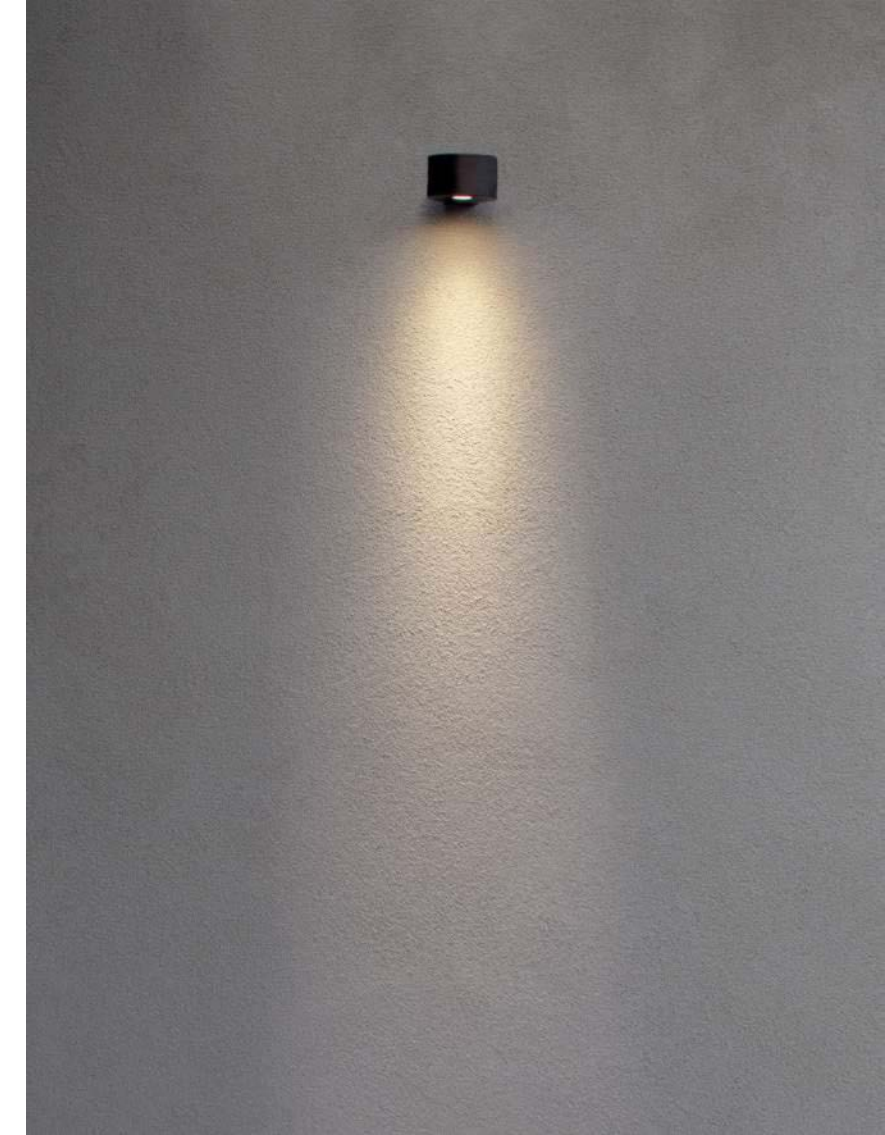
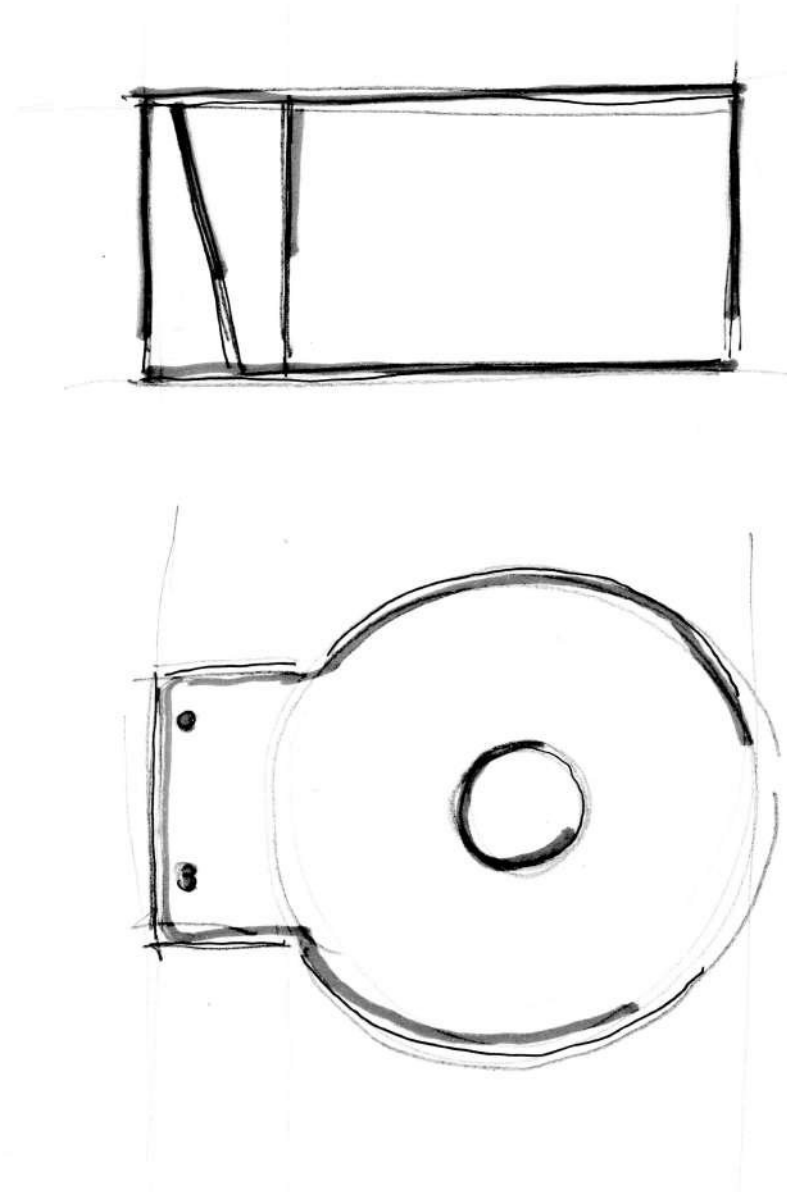

Translations

EN A mirror of water where everything that surrounds it is reflected inside. It is always getting inspiration from nature and its from this that LOCH was born, sinuous and compact, conceived to illuminate the surfaces of the walls, and at the same time dressing of their own material thanks to the reflections that this object brings inside.

FR Un miroir d'eau où se reflète tout ce qui l'entoure. Ici aussi, ce sont la nature et ses phénomènes qui ont inspiré LOCH, un produit sinueux et compact, conçu pour illuminer les surfaces des murs, et en même temps revêtir leur propre habiller de lumière le matériau même du mur grâceaux reflets que cet éclairage crée à l'intérieur même de celui-ci.

DE Ein Spiegel aus Wasser, in dem sich alles, was ihn umgibt, reflektiert wird. Stets von der Natur und ihren Phänomenen inspiriert, entstand LOCH, gewunden und kompakt, konzipiert, um die Oberflächen der Wände zu beleuchten und gleichzeitig dank der Reflexionen, die dieses Objekt auf das Innere überträgt, ihre eigene Umgebung zu umhüllen.

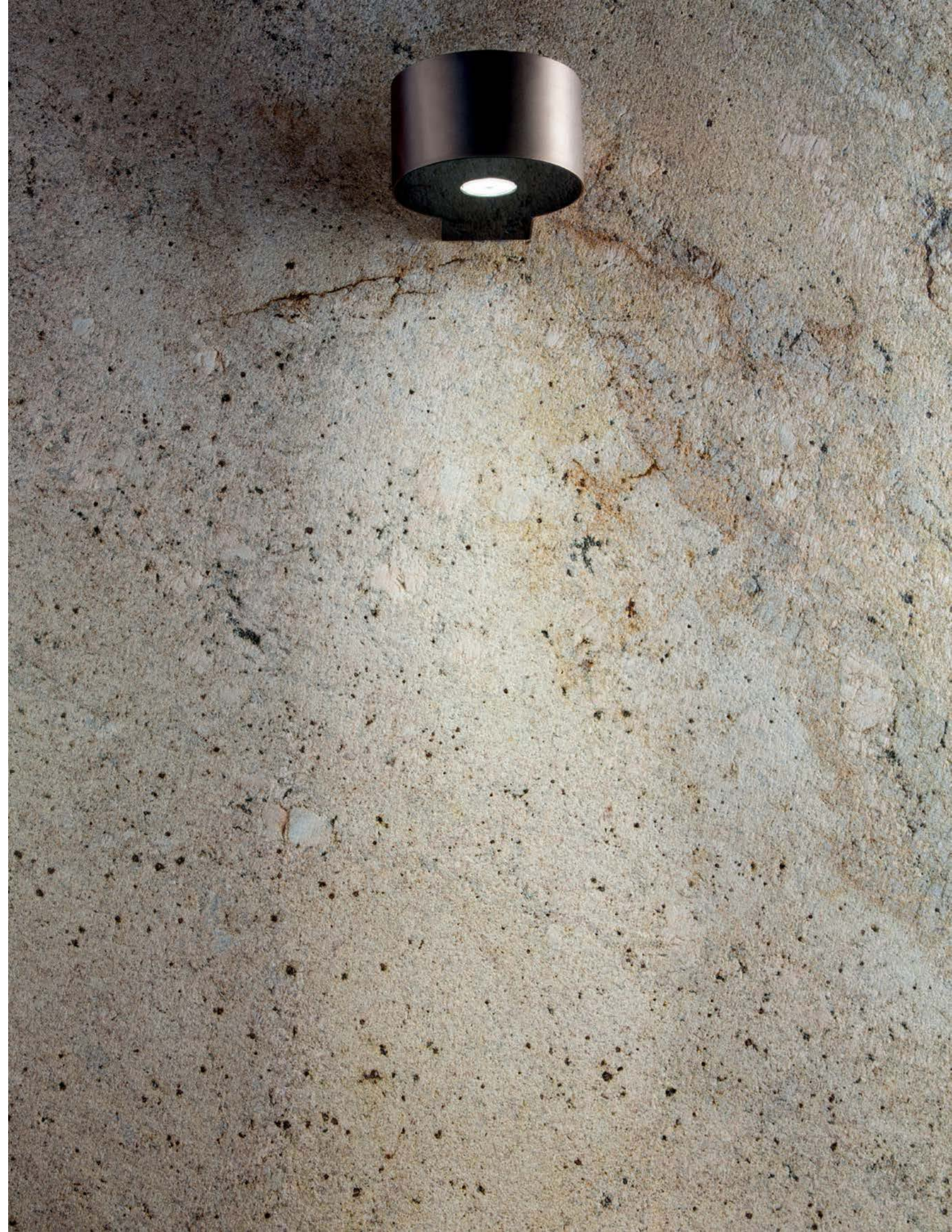





---

#### About

Compatto e discreto, il suo volume ridotto esce dalle pareti a cui viene applicato. Incastonato come le sedimentazioni che troviamo nelle rocce capaci di disegnare motivi che ben si integrano nella parete, queste forme sono presenti con una specifica funzione anche negli ambienti più aspri, ed ecco che da questo concetto nasce DYKE.



Inox Natural



Inox Graphite



Inox Bronze





Inox Natural



Inox Graphite



Inox Bronze





Inox Natural



Inox Graphite



Inox Bronze





Inox Natural



Inox Graphite



Inox Bronze





Inox Natural



Inox Graphite

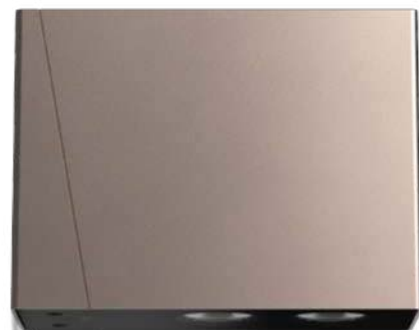

Inox Bronze





Inox Natural



Inox Graphite



Inox Bronze



EN The spacer integrated within the lamp body makes the product compact. Made of AISI 316L stainless steel. Flush black silk-screened glass extra-clear tempered, 4 mm thick. Mono and bi-emission versions with one, two or three LEDs for different design needs. 21°, 45° and 65° optics at 2700K, 3000K and 4000K. Integrated power supply. HCT surface finish available in three variants.

ITA Il distanziale integrato con il corpo lampada rende il prodotto compatto. Realizzato in acciaio inox AISI 316L. Vetro a filo serigrafato nero, temperato extra-chiaro di spessore 4 mm. Versioni mono e bi-emissione con uno, due o tre LED per le diverse esigenze progettuali. Ottiche da 21°, 45° e 65° da 2700K, 3000K e 4000K. Alimentatore integrato. Finitura superficiale HCT disponibile in tre varianti.

FR L'entretoise intégrée au corps de la lampe rend le produit compact. En acier inox AISI 316L. Verre affleuré sérigraphié noir, trempé extra-clair de 4 mm d'épaisseur. Versions mono et bi-émission avec une, deux ou trois LED, selon les exigences de conception. Optiques de 21°, 45° et 65° à 2700K, 3000K et 4000K. Alimentation intégrée. Finition de surface HCT disponible en trois variantes.

DE Der im Leuchtenkörper integrierte Abstandhalter macht das Produkt kompakt. Hergestellt aus Edelstahl AISI 316L. Bündiges, extra klares gehärtetes schwarzes Siebdruckglas 4 mm dick. Versionen Einzelleuchte und Doppelleuchte mit einer, zwei oder drei LEDs für unterschiedliche Designanforderungen. Optiken von 21°, 45° und 65° von 2700K, 3000K und 4000K. Integriertes Netzteil. HCT-Oberflächenbearbeitung in drei Ausführungen erhältlich.

DYKE M01



Colour			Emission
2700 K 543 lm	3000 K 550 lm	4000 K 613 lm	
Power 5 W			Codes Technical details
		21° 45° 65°	
IP66		IK08	

DYKE M02

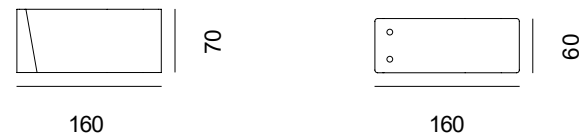

Colour			Emission
2700 K 1087 lm	3000 K 1100 lm	4000 K 1227 lm	
Power 10 W			Codes Technical details
		21° 45° 65°	
IP66		IK08	

DYKE M03

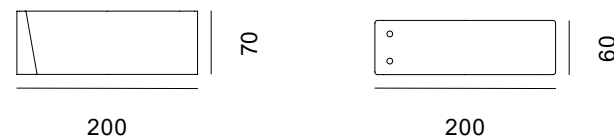

Colour			Emission
2700 K 1630 lm	3000 K 1650 lm	4000 K 1840 lm	
Power 15 W			Codes Technical details
		21° 45° 65°	
IP66		IK08	

DYKE B01

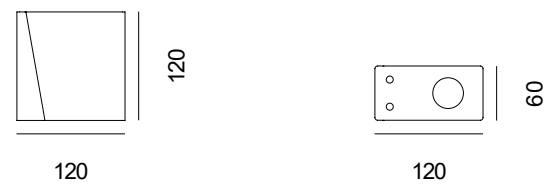

Colour			Emission
2700 K 2 x 543 lm	3000 K 2 x 550 lm	4000 K 2 x 613 lm	
Power 2 x 5 W			Codes Technical details
		21° + 21° 45° + 45° 65° + 65°	
IP66		IK08	

DYKE B02

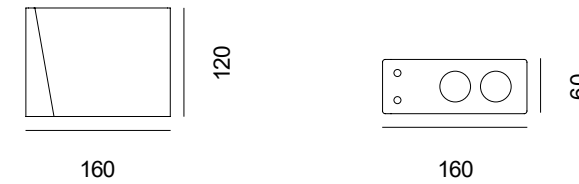

Colour			Emission
2700 K 2 x 1087 lm	3000 K 2 x 1100 lm	4000 K 2 x 1227 lm	
Power 2 x 10 W			Codes Technical details
		21° + 21° 45° + 45° 65° + 65°	
IP66		IK08	

DYKE B03

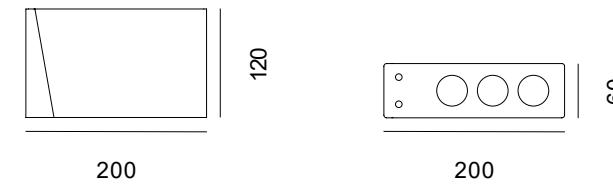

Colour			Emission
2700 K 2 x 1630 lm	3000 K 2 x 1650 lm	4000 K 2 x 1840 lm	
Power 2 x 15 W			Codes Technical details
		21° + 21° 45° + 45° 65° + 65°	
IP66		IK08	



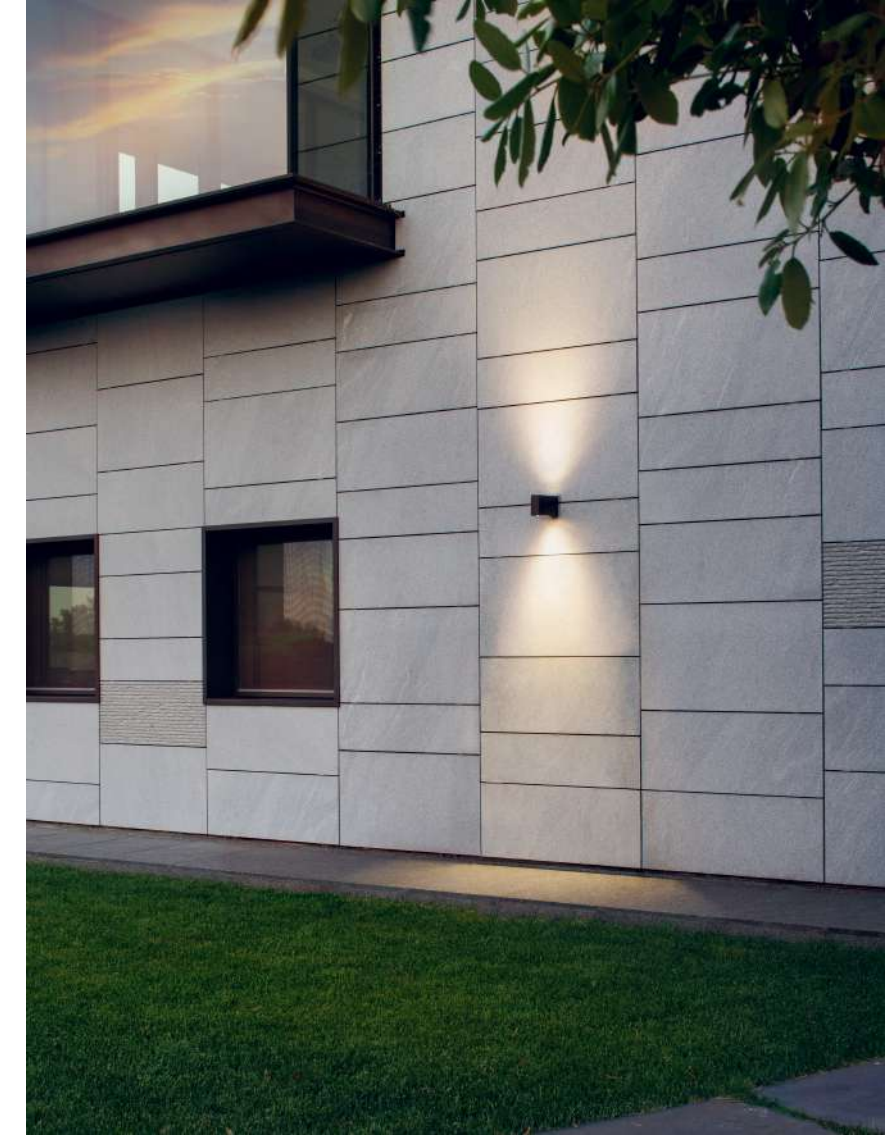
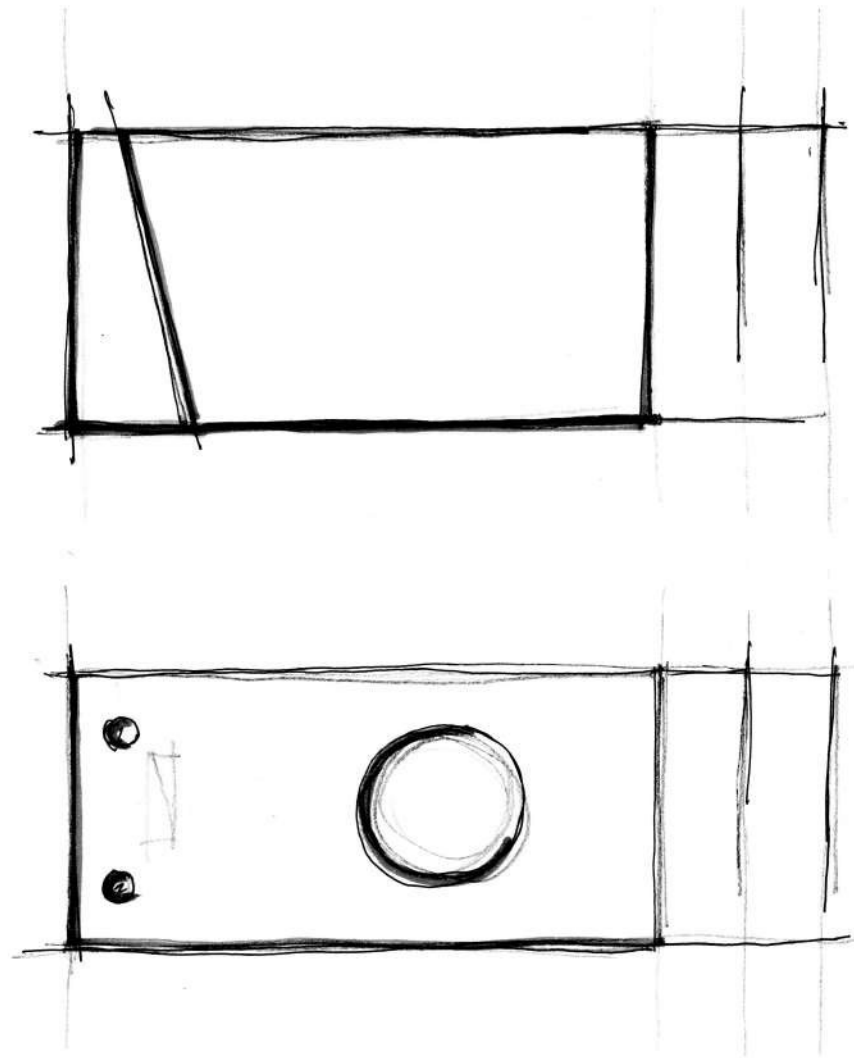

Translations

EN Compact and sober, its reduced volume emerges from the walls to which it is applied. Set like the sedimentation that we find in rocks. Capable of drawing motifs that well integrate themselves into the wall, these shapes are present with a specific function even in the harshest environments, and hence that from this concept, DYKE is born.

FR Compact et discret, son volume réduit émerge des murs sur lesquels il est appliqué. Comme les sédimentations encastrées dans les roches et qui forment des motifs qui s'intègrent au mur, ces formes sont présentes avec une fonction spécifique même dans les environnements les plus rudes. DYKE est né de ce concept-là.

DE Kompakt und diskret, tritt seine kleine Größe aus den Wänden hervor, auf denen es angebracht ist. Wie die Sedimentierung, die wir in Gesteinen finden, die in der Lage sind, Motive zu zeichnen, die sich gut in die Wand integrieren, sind diese Formen selbst in den rauesten Umgebungen mit einer bestimmten Funktion präsent, und genau aus diesem Konzept entstand DYKE.

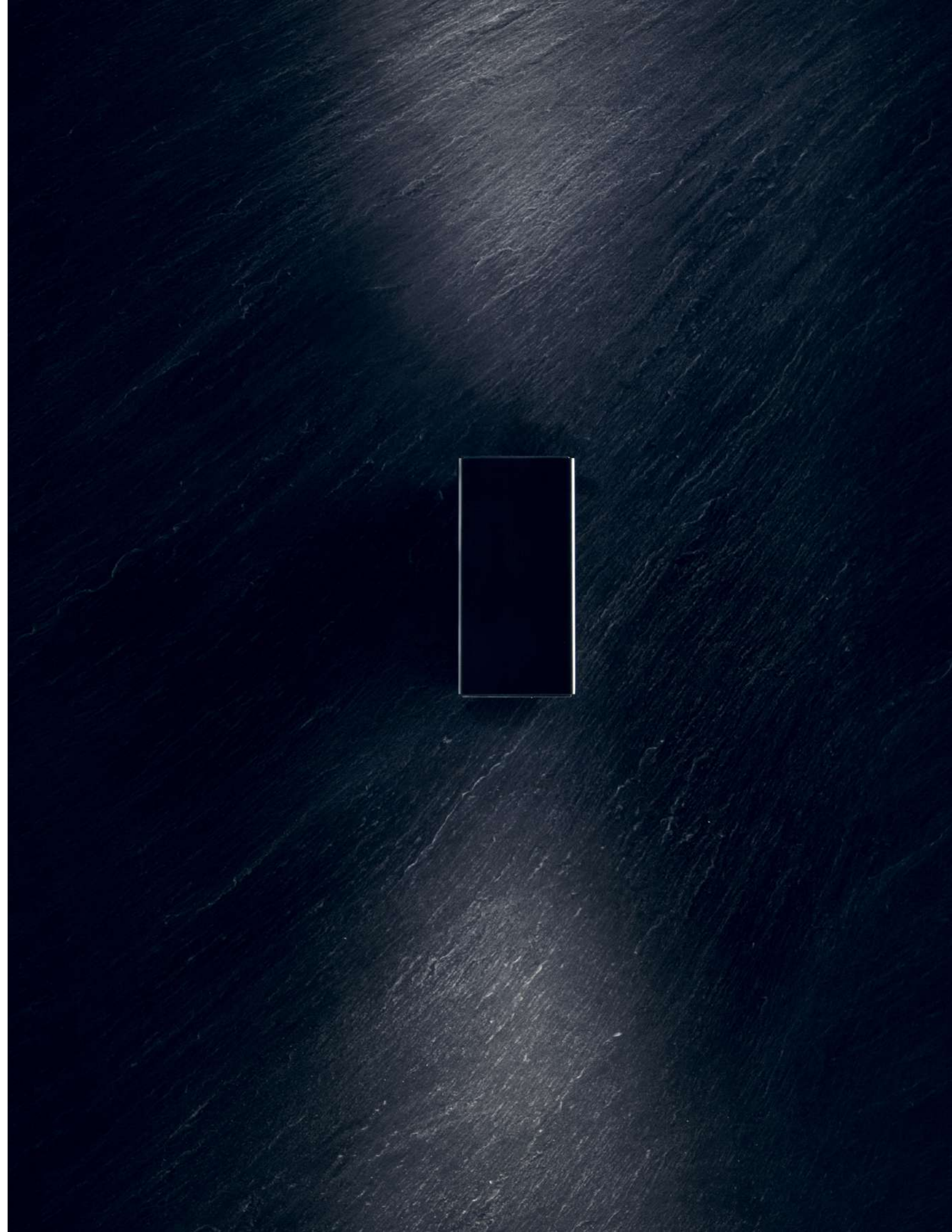
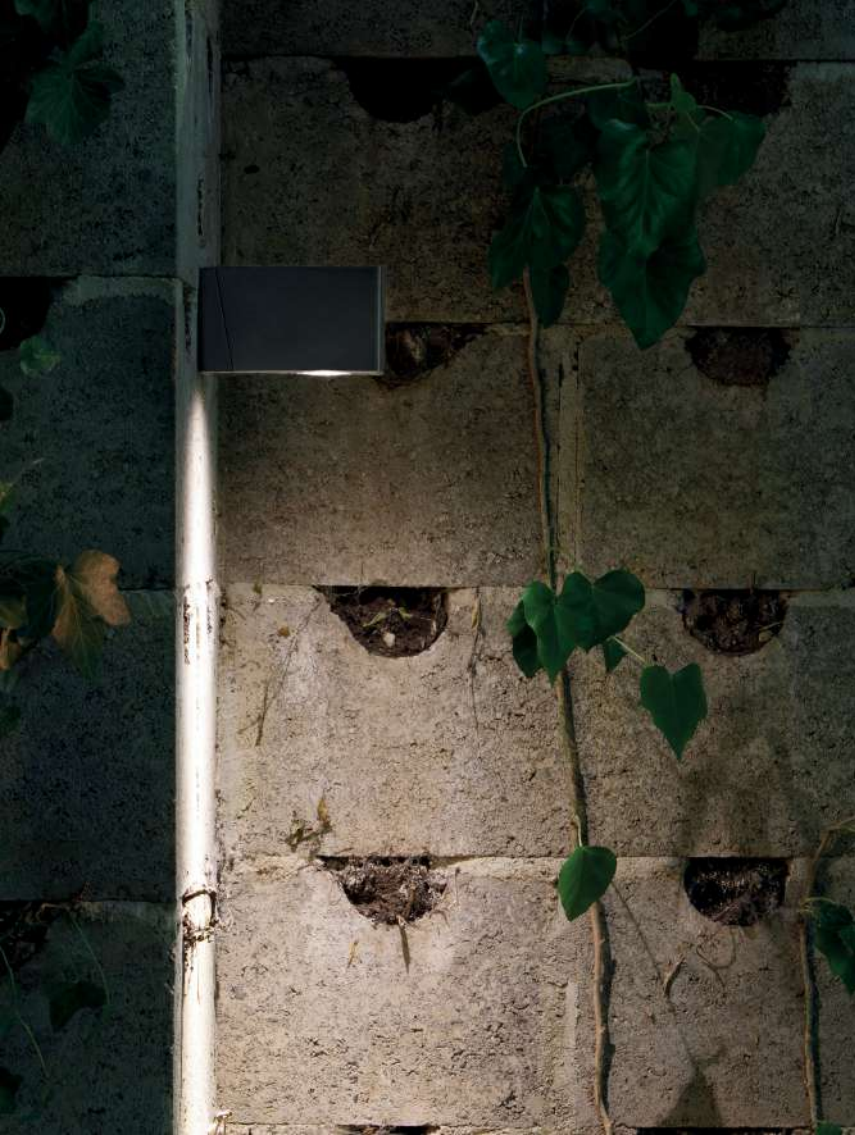



# SILL

---

## About

Volumi che escono dalle superfici in modo armonico e lineare raccontandoci una storia. SILL prende ispirazione dagli omonimi sills, composizioni orizzontali di strati di roccia a davanzale, che sbalzando fuori dalla parete disegnano intriganti geometrie.



Inox Natural



Inox Graphite



Inox Bronze





Inox Natural



Inox Graphite



Inox Bronze



EN The spacer integrated with the lamp body makes the product compact. Made of AISI 316L stainless steel. Flush black silk-screened glass extra-clear tempered, 4 mm thick. Stainless steel screws with colour matched to the finish. Mono and bi-emission versions with three LEDs for greater light output. 21°, 45° and 65° optics at 2700K, 3000K and 4000K. Integrated power supply. HTC surface finish available in three variants.

ITA Il distanziale integrato con il corpo lampada rende il prodotto compatto. Realizzato in acciaio inox AISI 316L. Vetro a filo serigrafato nero, temperato extra-chiaro, spessore 4 mm. Viti in acciaio inox con colorazione abbinata alla finitura. Versioni mono e bi-emissione con tre LED per una maggiore emissione luminosa. Ottiche da 21°, 45° e 65° da 2700K, 3000K e 4000K. Alimentatore integrato. Finitura superficiale HTC disponibile in tre varianti.

FR L'entretoise intégrée au corps de la lampe rend le produit compact. En acier inox AISI 316L. Verre affleuré sérigraphié noir, trempé extra-clair de 4 mm d'épaisseur. Vis en acier inox. Couleur assortie à la finition. Versions mono et bi-émission avec trois LED pour un meilleur rendement lumineux. Optiques de 21°, 45° et 65° à 2700K, 3000K et 4000K. Alimentation intégrée. Finition de surface HTC disponible en trois variantes.

DE Der im Leuchtenkörper integrierte Abstandhalter macht das Produkt kompakt. Hergestellt aus Edelstahl AISI 316L. Bündiges, extra klares gehärtetes schwarzes Siebdruckglas 4 mm dick. Schrauben aus Edelstahl, farblich auf die Endbearbeitung abgestimmt. Versionen Einzelleuchte und Doppelleuchte mit drei LED für mehr Lichtleistung. Optiken von 21°, 45° und 65° von 2700K, 3000K und 4000K. Integriertes Netzteil. HTC-Oberflächenbearbeitung in drei Ausführungen erhältlich.

SILL M03

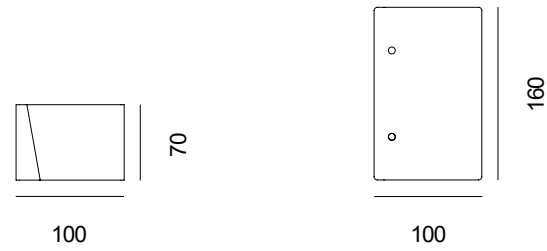

Colour			Emission
2700 K 1630 lm	3000 K 1650 lm	4000 K 1840 lm	
Power 15 W			45°
 Codes Technical details			65°
IP66		IK08	

SILL B03

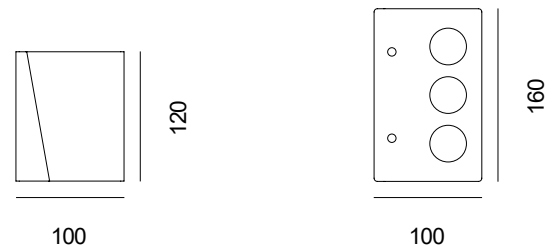

Colour			Emission
2700 K 2 x 1630 lm	3000 K 2 x 1650 lm	4000 K 2 x 1840 lm	
Power 2 x 15 W			45° + 45°
 Codes Technical details			65° + 65°
IP66		IK08	

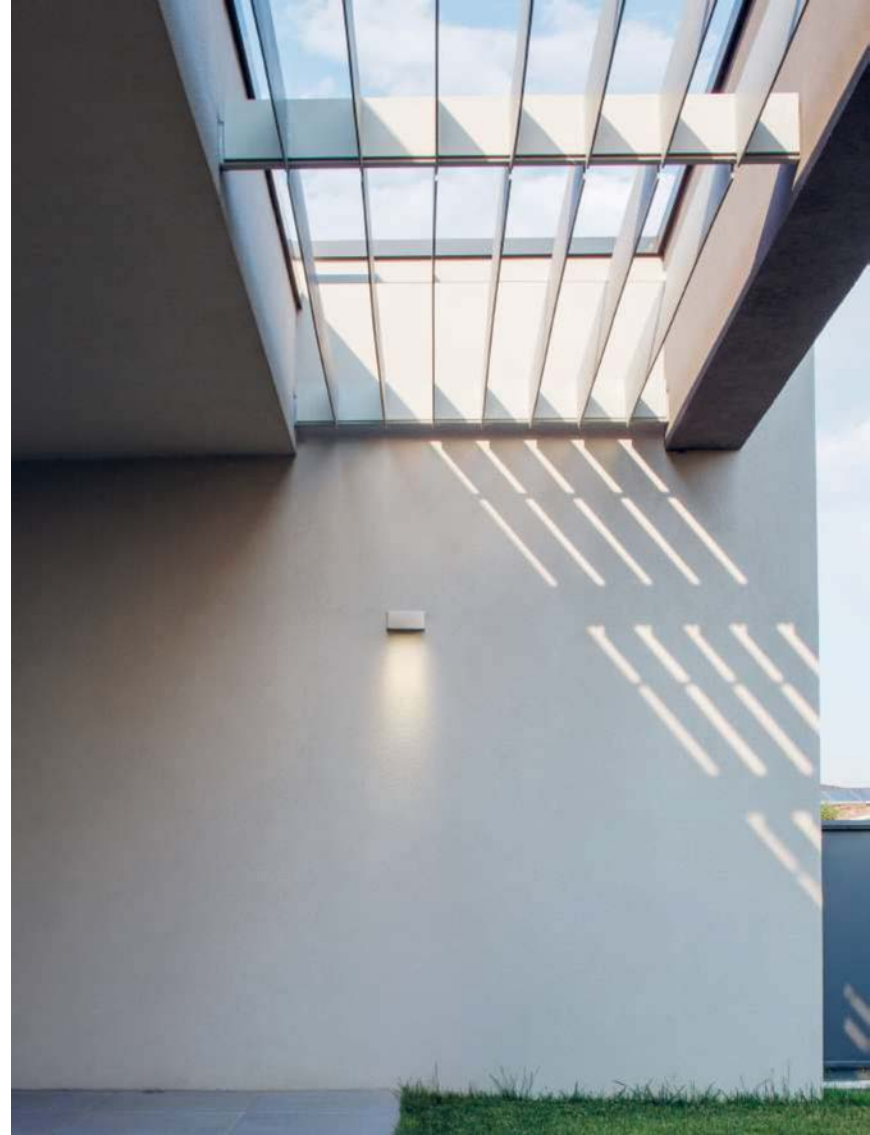

Translations

EN Volumes that come out of the surfaces in a harmonious and linear way, telling us a story.

SILL is inspired by the homonymous sills, the horizontal compositions of sill-shaped rock layers which jut out from the wall to draw intriguing geometries.

FR Des volumes qui sortent des surfaces de manière harmonieuse et linéaire et qui nous racontent une histoire. SILL s'inspire des seuils homonymes, des compositions horizontales de couches rocheuses en forme de seuil, qui dépassent du mur pour dessiner des géométries intrigantes.

DE Volumen, die harmonisch und geradlinig aus den Oberflächen hervortreten und uns eine Geschichte erzählen. SILL ist inspiriert von den gleichnamigen Sills, horizontalen Kompositionen von Felsriegelschichten, die aus der Wand herausragen, um faszinierende Geometrien zu zeichnen.



# FOCAL

---

## About

Il mettere a fuoco, il punto focale, il punto-chiave, il centro concettuale, è proprio questo che FOCAL fa ovunque lo si installi, consente una trasversalità applicativa notevole, per mettere a fuoco, illuminandoli, i particolari architettonici, ma anche elementi naturali come arbusti e zone piantumate valorizzando l'atmosfera circostante.

# D

# 50



Inox Natural



Inox Graphite



Inox Bronze





# D

# 70



Inox Natural



Inox Graphite



Inox Bronze



STRAL

EN Projector with locking ring with parallel lines knurling. Spike and projector in AISI 316L stainless steel. Extra-clear tempered glass 4 mm thick. Power cable inserted inside the spike for protection against cuts and accidental damage. Head axial rotation of 180°. GU4 lamp holder for D-50 version with remote power supply or GU10 for D-70 version. HCT surface finish available in three variants.

ITA Proiettore con ghiera di chiusura dalla zigrinatura a linee parallele. Picchetto d'infissione e proiettore in acciaio inox AISI 316L. Vetro temperato extra-chiaro di spessore 4 mm. Cavo d'alimentazione inserito all'interno del picchetto per la protezione da tagli e danni accidentali. Rotazione assiale della testa di 180°. GU4 per versione D-50 con alimentatore remoto e GU10 per versione D-70. Finitura superficiale HCT disponibile in tre varianti.

FR Projecteur avec bague de verrouillage à cannelures aux lignes parallèles. Piquet de fixation et projecteur en acier inox AISI 316L. Verre trempé extra-clair de 4 mm. Câble d'alimentation à l'intérieur du piquet pour protéger contre les coupures et les accidents. Rotation axiale de la tête de 180°. GU4 pour la version D-50 avec alimentation à distance et GU10 pour la version D-70. Finition de surface HCT disponible en trois variantes.

DE Projektor mit Sicherungsring mit Rändelung paralleler Linien. Erdspeiß und Projektor aus Edelstahl AISI 316L. Extra klares gehärtetes Glas 4 mm dick. Stromkabel zum Schutz vor Schnitten und versehentlicher Beschädigung im Inneren des Erdspeiß eingeführt. Axiale Drehung des Kopfes von 180°. GU4 für die D-50-Version mit Fernstromversorgung und GU10 für die D-70-Version. HCT-Oberflächenbearbeitung in drei Ausführungen erhältlich.

FOCAL D50

GU 4

12 V

Codes Technical details

Emission

IP66 IK07

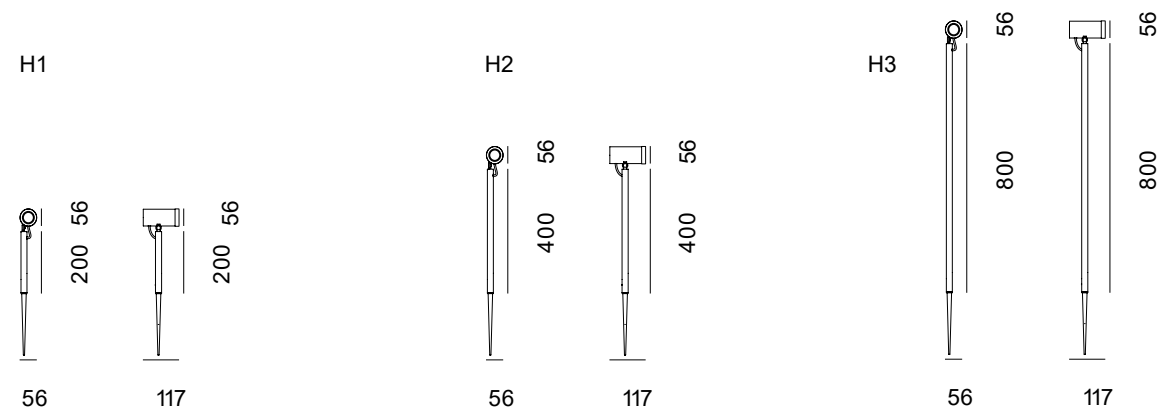

FOCAL D70

GU 10

220 V

Codes Technical details

Emission

IP66 IK08

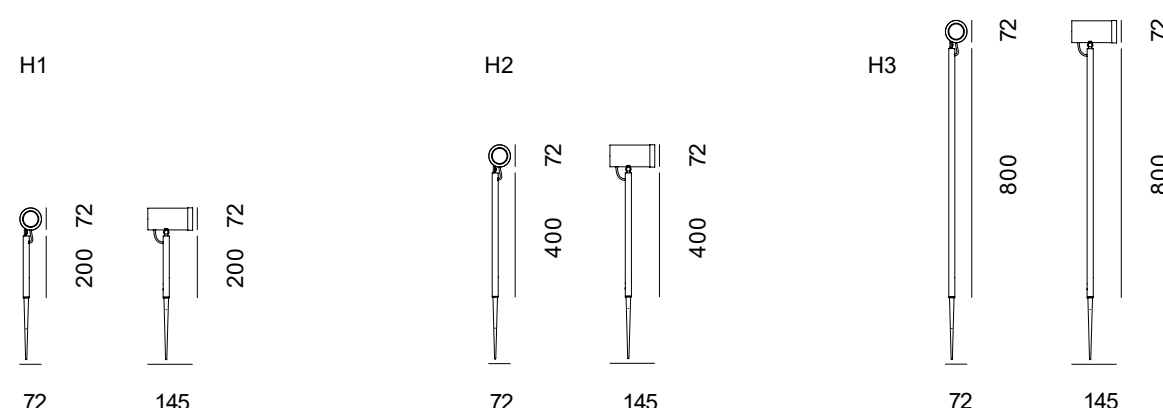

Translations

EN The focus, the focal point, the key-point, the conceptual centre, is what FOCAL does wherever it is installed. It allows a remarkable applicative transversality, to focus, illuminating architectural details, but also natural elements such as Shrubs and planted areas, enhancing the surrounding atmosphere.

FR Le foyer, le point focal, le point-clé, le centre conceptuel, c'est précisément ce que va créer FOCAL partout où il est installé. Il permet une transversalité d'application remarquable qui permet de focaliser la lumière sur les détails architecturaux, mais aussi sur les éléments naturels comme les arbustes et des espaces plantés, valorisant ainsi l'atmosphère environnante.

DE Der Fokus, der Mittelpunkt, der Schlüsselpunkt, das konzeptionelle Zentrum, genau das ist es, was FOCAL überall dort definiert, wo es installiert ist, es ermöglicht eine bemerkenswerte applicative Transversalität, um die architektonischen Details, aber auch natürliche Elemente wie Sträucher und bepflanzte Bereiche, die die umgebende Atmosphäre verbessern, zu fokussieren und zu beleuchten.





# BENTH

---

## About

Piegarsi senza spezzarsi, resistere ai cambiamenti e alle variabili per imparare a gestire ogni situazione. BENTH nasce per questo, adattabile e sottile, la sua luce si orienta per essere proiettata su superfici, foglie, siepi e piante, il suo corpo si mimetizza nell'ambiente creando insieme un'atmosfera unica e poetica.

# T

# 100



Inox Natural



Inox Graphite



Inox Bronze



STRAL

EN Projector and spike in AISI 316L stainless steel. Adjustable head, variable and adaptable spike height. Black silk-screened extra-clear tempered glass 4 mm thick. Power cable inserted inside the spike for cuts and accidental damage protection. 4 LEDs with 20° and 45° optics at 2700K, 3000K and 4000K. Remote power supply. HCT surface finish available in three variants.

ITA Proiettore e picchetto d'infissione in acciaio inox AISI 316L. Testa orientabile e altezza del picchetto variabile e adattabile. Vetro serigrafato nero temperato extra-chiaro di spessore 4 mm. Cavo d'alimentazione inserito all'interno del picchetto per la protezione da tagli e danni accidentali. 4 LED con ottiche da 20° e 45° con temperature colore da 2700K, 3000K e 4000K. Alimentatore remoto. Finitura superficiale HCT disponibile in tre varianti.

FR Projecteur et piquet de fixation en acier inox AISI 316L. Tête réglable et hauteur du piquet variable et adaptable. Verre sérigraphié noir trempé extra-clair de 4 mm d'épaisseur. Câble d'alimentation à l'intérieur du piquet pour protéger contre les coupures et les accidents. 4 LED avec optiques de 20° et 45° avec températures de couleur de 2700K, 3000K et 4000K. Alimentation à distance. Finition de surface HCT disponible en trois variantes.

DE Projektor und Erdspieß aus Edelstahl AISI 316L. Verstellbarer Kopf und variable und anpassbare Erdspießhöhe. Extra klares Siebdruckglas 4 mm dick. Stromkabel zum Schutz vor Schnitten und versehentlicher Beschädigung im Inneren des Erdspieß eingeführt. 4 LEDs mit 20° und 45° Optik mit 2700K, 3000K und 4000K Farbtemperaturen. Fernstromversorgung. HCT-Oberflächenbearbeitung in drei Ausführungen erhältlich.

BENTH T100

Colour			Emission
2700 K 409 lm	3000 K 433 lm	4000 K 466 lm	
Power 5 W			20°
 Codes Technical details			45°

IP65 IK07 Driver & accessories p. 238

H1

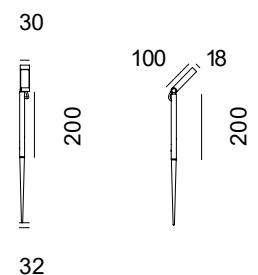

H2

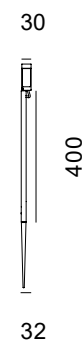

H3

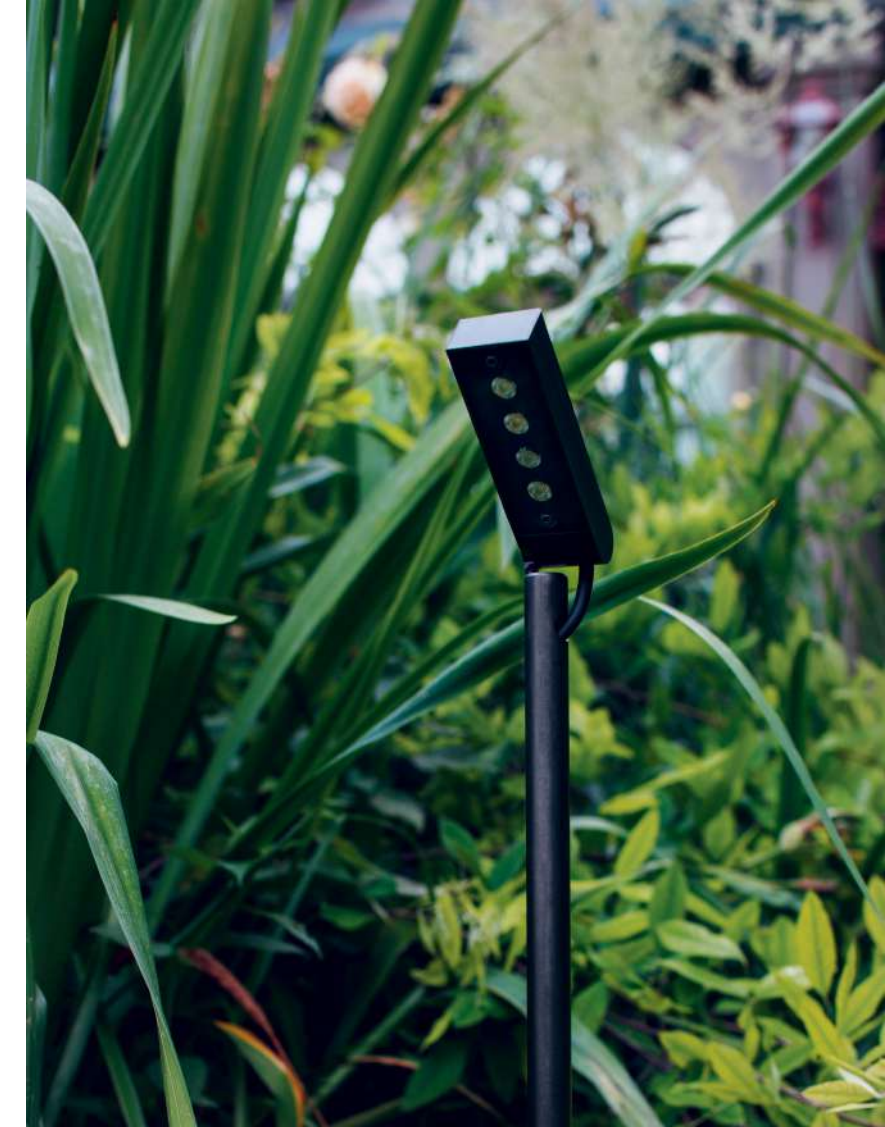
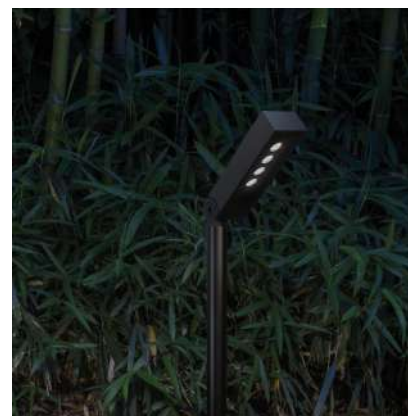
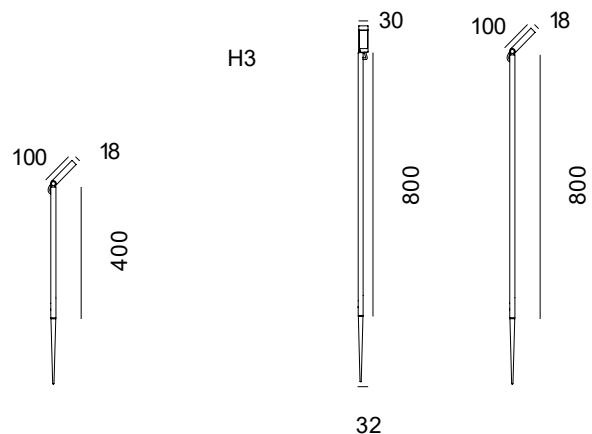

Translations

EN Bending without breaking, resisting changes and variables to learn how to manage every situation.

BENTH was born for this purpose, thin and adaptable its light is oriented to be projected onto surfaces, leaves, hedges and plants its body camouflaged in the environment, creating a unique and poetic atmosphere.

FR Plier sans casser, résister aux changements et aux variables pour apprendre à gérer chaque situation. BENTH a été créé pour satisfaire ces exigences. Adaptable et délicat, sa lumière est parfaitement conçue pour être projetée sur des surfaces, feuilles, haies et plantes. Son corps, lui, se camoufle dans l'environnement, créant une atmosphère unique et poétique.

DE Biegen ohne zu brechen, Widerstand gegen Veränderungen und Variablen, um zu lernen, jede Situation zu bewältigen. BENTH wurde dafür geschaffen, anpassungsfähig und subtil, sein Licht ist darauf ausgerichtet, auf Flächen, Blätter, Hecken und Pflanzen projiziert zu werden, sein Körper ist in der Umgebung getarnt und schafft gemeinsam eine einzigartige und poetische Atmosphäre.

# DYKE ROTO



---

## About

Una versione rotante di DYKE che abbina al suo volume ridotto una staffa con snodo che gli consente movimenti circolari sull'asse a cui viene applicato, rendendolo estremamente funzionale. Da questo concetto nasce DYKEROTO, per donare ai progetti fantasia e adattabilità.



Inox Natural



Inox Graphite



Inox Bronze







Inox Natural



Inox Graphite



Inox Bronze



# M



Inox Natural



Inox Graphite



Inox Bronze

# 03



EN The spacer integrated with the lamp body makes the product compact. Bracket with joint for 360° rotation on one axis. Made of AISI 316L stainless steel. Flush black silk-screened glass extra-clear tempered, 4 mm thick. Single-emission version with one, two or three LEDs for different design needs. 21°, 45° and 65° optics at 2700K, 3000K and 4000K. Integrated power supply. HCT surface finish available in three variants.

ITA Il distanziale integrato con il corpo lampada rende il prodotto compatto. Staffa con snodo per rotazioni a 360° su un asse. Realizzato in acciaio inox AISI 316L. Vetro a filo serigrafato nero, temperato extra-chiaro di spessore 4 mm. Versione mono-emissione con uno, due o tre LED per le diverse esigenze progettuali. Ottiche da 21°, 45° e 65° da 2700K, 3000K e 4000K. Alimentatore integrato. Finitura superficiale HCT disponibile in tre varianti.

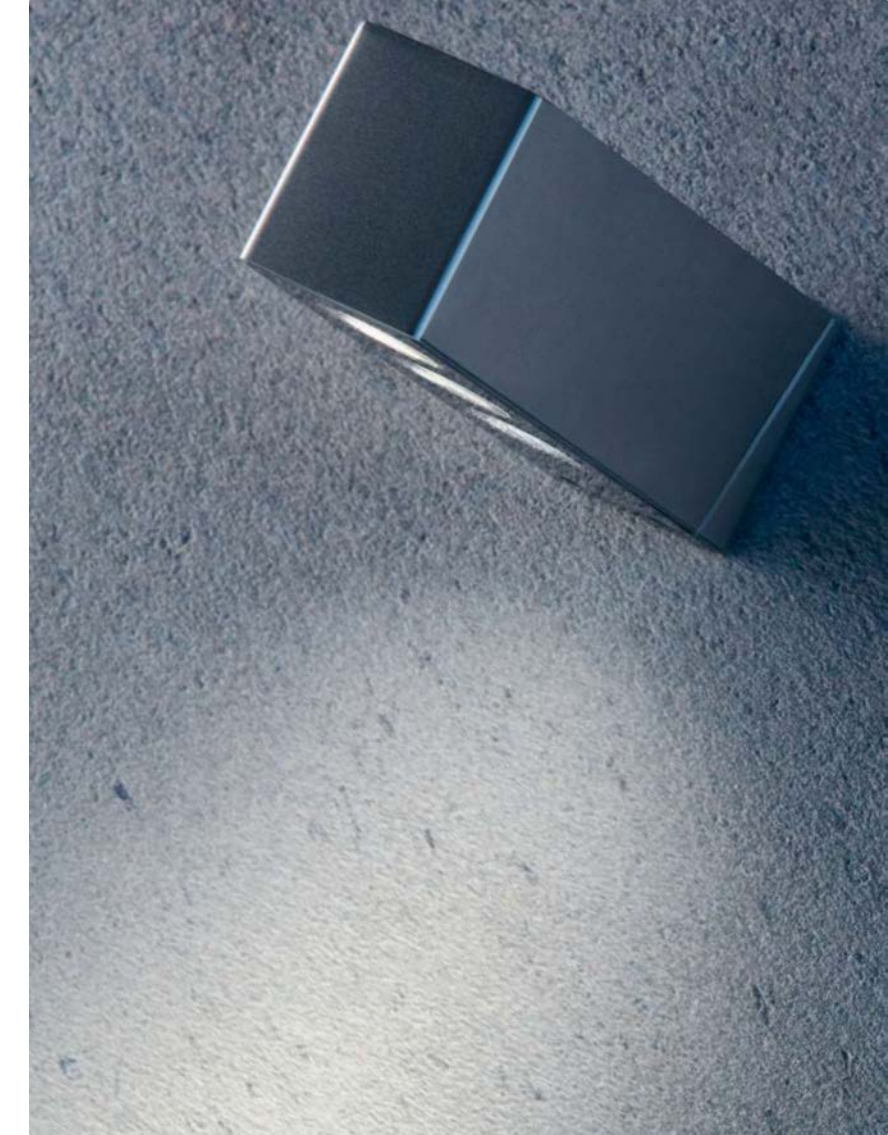

FR L'entretoise intégrée au corps de la lampe rend le produit compact. Support articulé pour rotation à 360° sur un axe. En acier inox AISI 316L. Verre affleurant sérigraphié noir, trempé extra-clair de 4 mm d'épaisseur. Version mono-émission avec une, deux ou trois LED, selon les exigences de conception. Optiques de 21°, 45° et 65° à 2700K, 3000K et 4000K. Alimentation intégrée. Finition de surface HCT disponible en trois variantes.

DE Der im Leuchtenkörper integrierte Abstandhalter macht das Produkt kompakt. Halterung mit Gelenk für 360° Drehung um eine Achse. Hergestellt aus Edelstahl AISI 316L. Bündiges, extra klares gehärtetes schwarzes Siebdruckglas 4 mm dick. Version Einzelleuchte mit einer, zwei oder drei LEDs für unterschiedliche Designanforderungen. Optiken von 21°, 45° und 65° von 2700K, 3000K und 4000K. Integriertes Netzteil. HCT-Oberflächenbearbeitung in drei Ausführungen erhältlich.





#### DYKEROTO M01



Colour			Emission
2700 K 543 lm	3000 K 550 lm	4000 K 613 lm	
Power 5 W	 Codes Technical details		
IP66   IK08  Orientable			



#### DYKEROTO M02

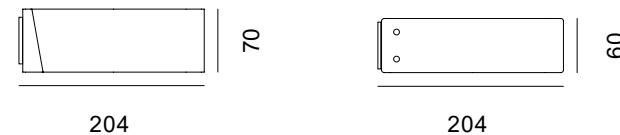

Colour			Emission
2700 K 1087 lm	3000 K 1100 lm	4000 K 1227 lm	
Power 10 W	 Codes Technical details		
IP66   IK08  Orientable			

#### DYKEROTO M03



Colour			Emission
2700 K 1630 lm	3000 K 1650 lm	4000 K 1840 lm	
Power 15 W	 Codes Technical details		
IP66   IK08  Orientable			

#### Translations

EN A rotating version of DYKE that combines its reduced volume with a bracket with a joint that allows circular movements on the axis to which it is applied, making it extremely functional.

From this concept comes DYKEROTO, to give projects imagination and adaptability.

FR Une version rotative de DYKE qui combine son volume réduit au support articulé qui permet des mouvements circulaires sur l'axe auquel il est appliqué, le rendant extrêmement fonctionnel. DYKEROTO est né de ce concept-là, pour donner de l'imagination et de l'adaptabilité aux projets.

DE Eine Drehversion von DYKE, die ihre kleine Größe mit einer Halterung mit einem Gelenk kombiniert, das kreisförmige Bewegungen auf der Achse ermöglicht, auf die sie angewendet wird, was sie äußerst funktional macht. Aus diesem Konzept entstand DYKEROTO, um den Projekten Fantasie und Anpassungsfähigkeit zu verleihen.



Product

# DYKE FLEX

---

## About

Compatto e discreto, il suo volume ridotto unito alla staffa che gli consente di orientarsi sul supporto a cui viene applicato lo rendono estremamente versatile. Da questo concetto nasce DYKEFLEX, la versione orientabile su doppio asse dello standard DYKE.

# M



Inox Natural



Inox Graphite



Inox Bronze

# 01





Inox Natural



Inox Graphite



Inox Bronze



# M



Inox Natural



Inox Graphite



Inox Bronze

# 03



EN The spacer integrated with the lamp body makes the product compact. Adjustable bracket to allow movements in all directions. Made of AISI 316L stainless steel. Flush black silk-screened glass extra-clear tempered, 4 mm thick.

Single-emission versions with one, two or three LEDs for different design needs. 21°, 45° and 65° optics at 2700K, 3000K and 4000K. Integrated power supply. HCT surface finish available in three variants.



ITA Il distanziale integrato con il corpo lampada rende il prodotto compatto. Staffa snodata per movimenti in tutte le direzioni. Realizzato in acciaio inox AISI 316L. Vetro a filo serigrafato nero, temperato extra-chiaro di spessore 4 mm. Versioni mono-emissione con uno, due o tre LED per le diverse esigenze progettuali. Ottiche da 21°, 45° e 65° da 2700K, 3000K e 4000K. Alimentatore integrato. Finitura superficiale HCT disponibile in tre varianti.

FR L'entretoise intégrée au corps de la lampe rend le produit compact. Support articulé pour des mouvements dans toutes les directions. En acier inox AISI 316L. Verre affleurant sérigraphié noir, trempé extra-clair de 4 mm d'épaisseur. Versions mono-émission avec une, deux ou trois LED, selon les exigences de conception. Optiques de 21°, 45° et 65° à 2700K, 3000K et 4000K. Alimentation intégrée. Finition de surface HCT disponible en trois variantes.

DE Der im Leuchtenkörper integrierte Abstandhalter macht das Produkt kompakt. Gelenkhalterung für Bewegungen in alle Richtungen. Hergestellt aus Edelstahl AISI 316L. Bündiges, extra klares gehärtetes schwarzes Siebdruckglas 4 mm dick. Versionen Einzelleuchte mit einer, zwei oder drei LEDs für unterschiedliche Designanforderungen. Optiken von 21°, 45° und 65° von 2700K, 3000K und 4000K. Integriertes Netzteil. HCT-Oberflächenbearbeitung in drei Ausführungen erhältlich.



#### DYKE FLEX M01



Colour			Emission
2700 K 543 lm	3000 K 550 lm	4000 K 613 lm	
Power 5 W	 Codes Technical details		
IP66   IK08  Orientable			



#### DYKE FLEX M02



Colour			Emission
2700 K 1087 lm	3000 K 1100 lm	4000 K 1227 lm	
Power 10 W	 Codes Technical details		
IP66   IK08  Orientable			

#### DYKE FLEX M03



Colour			Emission
2700 K 1630 lm	3000 K 1650 lm	4000 K 1840 lm	
Power 15 W	 Codes Technical details		
IP66   IK08  Orientable			



#### Translations

EN Compact and sober, its reduced volume combined with the bracket that allows it to orient itself on the support to which it is applied, make it extremely versatile. From this concept comes DYKEFLEX, the double-axis swivel version of the standard DYKE.

FR Compact et discret, son volume réduit combiné au support qui lui permet de s'orienter sur le support sur lequel il est appliqué le rend extrêmement polyvalent. DYKEFLEX est né de ce concept-là, il est la version pivotante à deux axes du produit standard DYKE.

DE Kompakt und diskret, seine kleine Größe in Kombination mit der Halterung, die es ermöglicht, es an der Unterlage auszurichten, auf der es angebracht ist, machen es äußerst vielseitig. Aus diesem Konzept entsteht DYKEFLEX, die doppelachsige Schwenkversion des DYKE-Standards.





# HOKU

---

## About

Freestanding a 360 gradi, così HOKU nasce per portare luce in modo tanto discreto quanto versatile, nei molteplici contesti architettonici. Proprio come gli oculi in architettura, di dimensioni ridotte portano luce non impattando sulle strutture, anche questo piccolo proiettore si integra per risolvere ogni esigenza progettuale: a pavimento, a parete e a soffitto.

# D

# 50



Inox Natural



Inox Graphite



Inox Bronze



D

70



Inox Natural



Inox Graphite



Inox Bronze



EN Closing ring with parallel lines knurling. Projector and housing base in AISI 316L stainless steel. Extra-clear tempered glass 4 mm thick. 360° rotation of the projector inside the base. GU4 lamp holder for the D-50 version with remote power supply and GU10 for the D-70 version. HCT surface finish available in three variants. Installation on the floor, wall, and ceiling through apposite bracket.

ITA Ghiera di chiusura con zigri-natura a linee parallele. Proiettore e base di alloggiamento in acciaio inox AISI 316L. Vetro temperato extra-chiaro di spessore 4 mm. Rotazione del proiettore all'interno della base a 360°. Attacco GU4 per la versione D-50 con alimentatore remoto e GU10 per la versione D-70. Finitura superficiale HCT disponibile in tre varianti. Installabile a pavimento, parete e soffitto tramite apposita staffa.

FR Bague de verrouillage à cannelures aux lignes parallèles. Projecteur et base de fixation en acier inox AISI 316L. Verre trempé extra-clair de 4 mm d'épaisseur. Rotation à 360° du projecteur à l'intérieur de la base. GU4 pour la version D-50 avec alimentateur à distance et GU10 pour la version D-70. Finition de surface HCT disponible en trois variantes. Peut être installé au sol, au mur et au plafond à l'aide d'un support spécial.

DE Verschlussring mit Rändelung in parallelen Linien. Projektor und Gehäusesockel aus Edelstahl AISI 316L. Extra klares gehärtetes Glas 4 mm dick. 360° Drehung des Projektors im Sockel. GU4-Anschluss für die D-50-Version mit Fernstromversorgung und GU10 für die D-70-Version. HCT-Oberflächenbearbeitung in drei Ausführungen erhältlich. Kann mit einer speziellen Halterung an Boden, Wand und Decke montiert werden.

#### HOKU D50

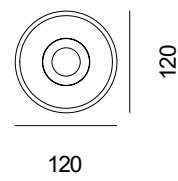
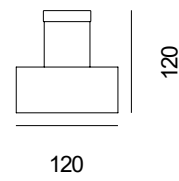

#### GU 4

12 V



Codes  
Technical details

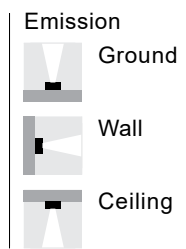

IP66 IK08 Orientable

#### HOKU D70

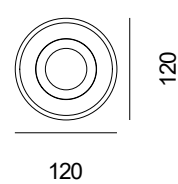
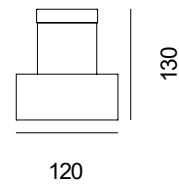

#### GU 10

220 V



Codes  
Technical details

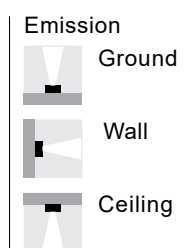

IP66 IK08 Orientable

#### Joint-less rotation

-30°

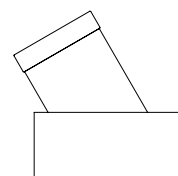

0°

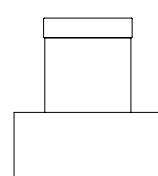

+30°

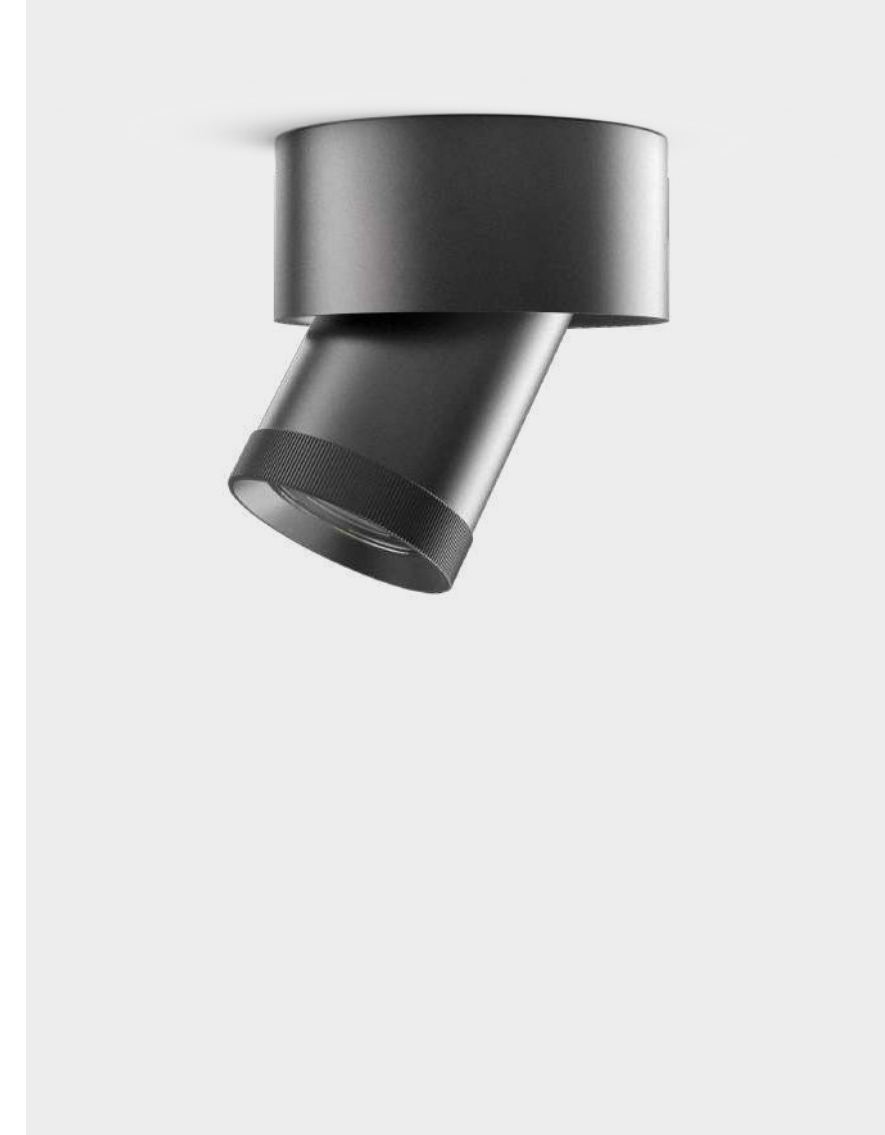
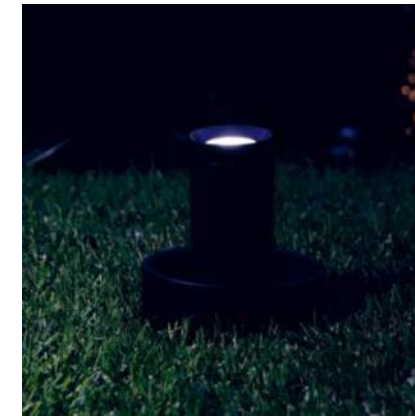
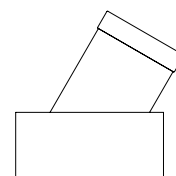

#### Translations

EN Freestanding at 360 degrees, HOKU was created to bring light in a way that is as discreet as it is versatile, in multiple architectural contexts. Just like the small oculi in architecture, they bring light without impacting the structures, this small projector also integrates itself to solve every design requirement: on the floor, on the wall and on the ceiling.

FR Freestanding à 360 degrés, HOKU a été créé pour apporter de la lumière de manière aussi discrète que polyvalente, dans de multiples contextes architecturaux. Tout comme les petits oculi en architecture qui apportent de la lumière sans impacter les structures, ce petit projecteur s'intègre parfaitement pour répondre à toutes les exigences de conception : sol, mur et plafond.

DE Um 360 Grad freistehend, wurde HOKU geschaffen, um Licht auf eine ebenso dezente wie vielseitige Weise in verschiedene architektonische Kontexte zu bringen. Wie die kleinen Oculi in der Architektur bringen sie Licht, ohne die Strukturen zu beeinträchtigen, auch dieser kleine Projektor lässt sich integrieren, um jede Designanforderung zu lösen: am Boden, an der Wand und an der Decke.



# KRAN



---

## About

Alcune opere d'arte, soprattutto nelle culture tribali, si rifanno alla natura e ai suoi abitanti. KRAN, è un'antica scultura la cui forma ha ispirato questo corpo illuminante, così protagonista e fiero; una composizione fantastica e surreale i cui occhi sembrano voler catturare l'attenzione dei presenti.

# M

# 01

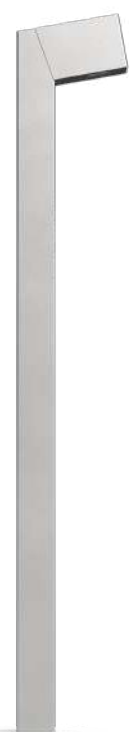

Inox Natural



Inox Graphite



Inox Bronze

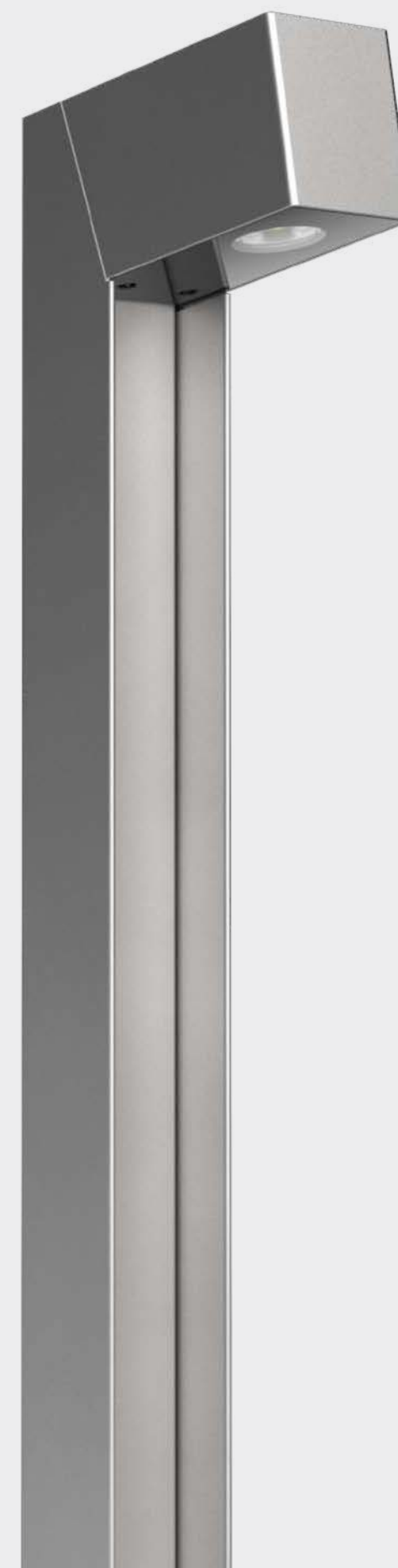

STRAL

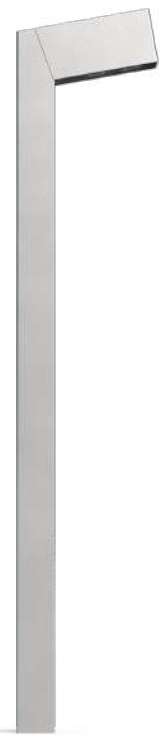

Inox Natural



Inox Graphite



Inox Bronze

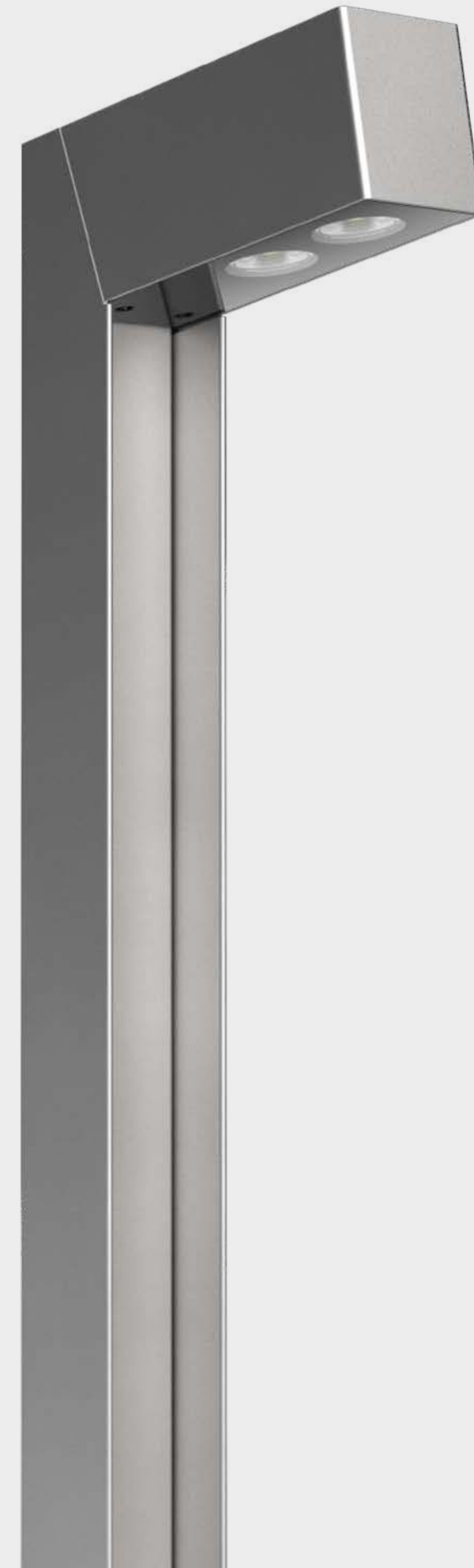

STRAL



# M

# 03



Inox Natural



Inox Graphite



Inox Bronze

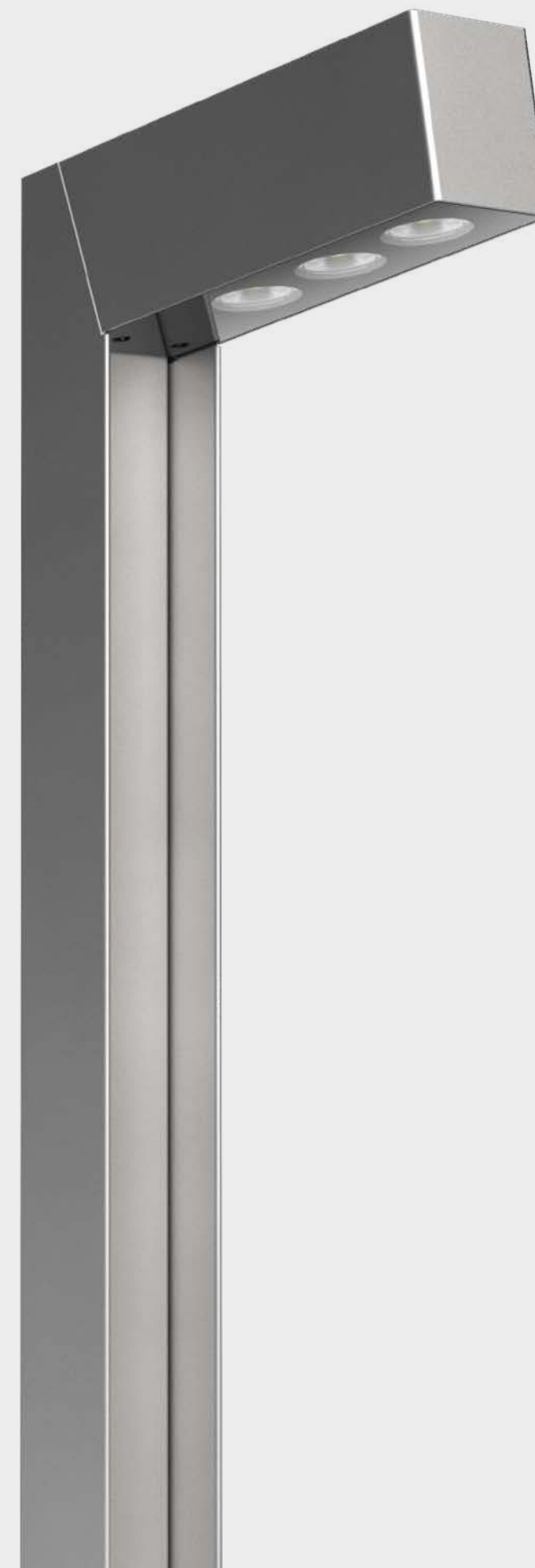

STRAL

EN Bollard available with height 60 cm and 90 cm made of AISI316L stainless steel. Pole top in versions with one, two or three LEDs for different design needs. 21°,45° and 65° optics at 2700K,3000K and 4000K Flush black silk-screened glass extra-clear tempered, 4 mm thick. Integrated power supply. Flange with anchor bolts for installation in concrete. HCT surface finish available in three variants.

ITA Paletto disponibile con altezza 60 cm e 90 cm realizzato in acciaio inox AISI 316L. Testa palo nelle versioni con uno, due o tre LED per le diverse esigenze progettuali. Ottiche da 21°,45° e 65° da 2700K,3000K e 4000K. Vetro a filo serigrafato nero, temperato extra-chiaro di spessore 4 mm. Alimentatore integrato. Flangia con tirafondi per installazione nel cemento. Finitura superficiale HCT disponibile in tre varianti.

FR Borne disponible en deux hauteurs de 60 et 90 cm, en acier inox AISI 316L. Tête de poteau dans les versions avec une, deux ou trois LED, selon les exigences de conception. Optiques de 21°,45° et 65° à 2700K,3000K et 4000K. Verre affleurant sérigraphié noir, trempé extra-clair de 4 mm d'épaisseur. Alimentation intégrée. Bride avec tirefonds pour installation dans le béton. Finition de surface HCT disponible en trois variantes.

DE Poller verfügbar mit Höhe 60 cm und 90 cm aus Edelstahl AISI 316L. Mastaufsatz in Versionen mit einer, zwei oder drei LEDs für unterschiedliche Designansprüche. Optiken von 21°,45° und 65° von 2700K,3000K und 4000K. Bündiges, extra klares gehärtetes schwarzes Siebdruckglas 4 mm dick. Integriertes Netzteil. Flansch mit Schwellenschrauben zum Einbau in Beton. HCT-Oberflächenbearbeitung in drei Ausführungen erhältlich.

### KRAN M03

Colour			Emission		
2700 K 1630 lm	3000 K 1650 lm	4000 K 1840 lm	21°	45°	65°
Power 15 W			Codes Technical details		
<div style="display: flex; gap: 5px;"> <div style="border: 1px solid black; border-radius: 10px; padding: 2px 5px;">IP66</div> <div style="border: 1px solid black; border-radius: 10px; padding: 2px 5px;">IK08</div> <div style="border: 1px solid black; border-radius: 10px; padding: 2px 5px;">Accessories p. 238</div> </div>					

H1

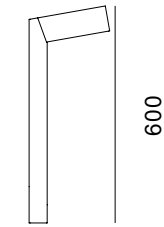

223

H2

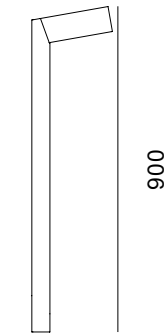

223

600

900



223

60



223

60

### KRAN M01

Colour			Emission		
2700 K 543 lm	3000 K 550 lm	4000 K 613 lm	21°	45°	65°
Power 5 W			Codes Technical details		
<div style="display: flex; gap: 5px;"> <div style="border: 1px solid black; border-radius: 10px; padding: 2px 5px;">IP66</div> <div style="border: 1px solid black; border-radius: 10px; padding: 2px 5px;">IK08</div> <div style="border: 1px solid black; border-radius: 10px; padding: 2px 5px;">Accessories p. 238</div> </div>					

H1

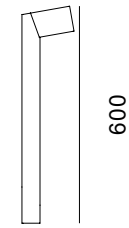

145

H2

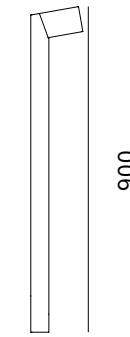

145

600

900

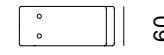

145

60

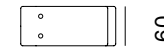

145

60

### KRAN M02

Colour			Emission		
2700 K 1087 lm	3000 K 1100 lm	4000 K 1227 lm	21°	45°	65°
Power 10 W			Codes Technical details		
<div style="display: flex; gap: 5px;"> <div style="border: 1px solid black; border-radius: 10px; padding: 2px 5px;">IP66</div> <div style="border: 1px solid black; border-radius: 10px; padding: 2px 5px;">IK08</div> <div style="border: 1px solid black; border-radius: 10px; padding: 2px 5px;">Accessories p. 238</div> </div>					

H1



184

H2

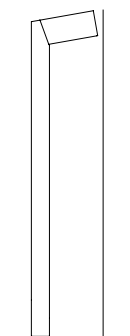

184

600

900

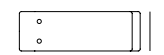

184

60

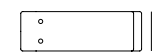

184

60

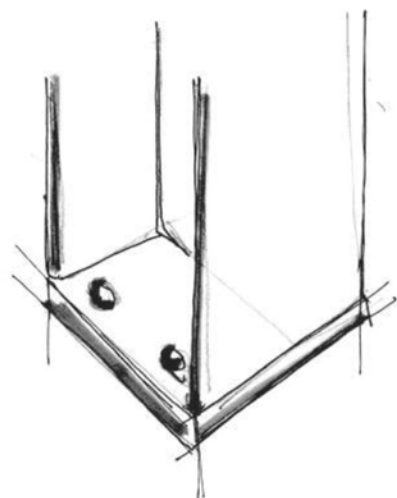
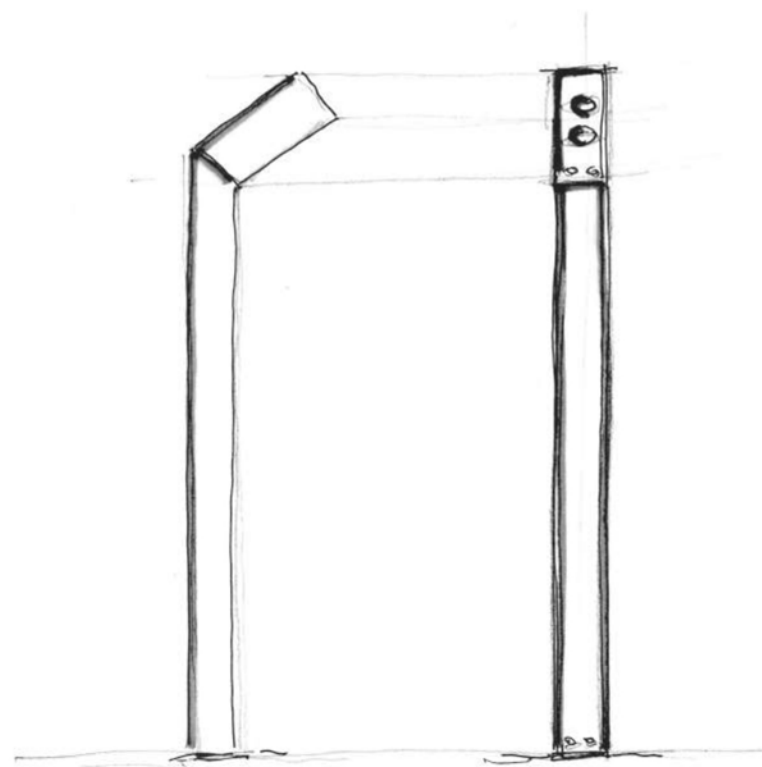

Translations

EN Some artworks, especially in tribal cultures, refer to nature and its inhabitants. KRAN, is an ancient sculpture whose shape has inspired this lighting fixture, so protagonist and proud; a fantastic and surreal composition whose eyes seem wanting to capture the attention of those present.

FR Certaines œuvres d'art, en particulier dans les cultures tribales, font référence à la nature et à ses habitants. KRAN est inspiré d'une sculpture antique dont la forme a inspiré ce corps lumineux, à la fois protagoniste et fier. C'est une composition fantastique et surréaliste dont les yeux semblent vouloir capter l'attention des personnes présentes.

DE Einige Kunstwerke, insbesondere in Stammeskulturen, beziehen sich auf die Natur und ihre Bewohner. KRAN ist eine antike Skulptur, deren Form diesen Leuchtkörper inspiriert hat, als Hauptfigur und stolz; eine fantastische und surreale Komposition, deren Augen die Aufmerksamkeit der Anwesenden auf sich ziehen wollen.







# DAN

---

## About

Dalla Costa d'Avorio trae ispirazione DAN, una statua molto rara, gelosamente nascosta all'interno delle capanne ed esposta solo durante importanti cerimonie rituali. Così altrettanto prezioso è questo nuovo bollard dalle linee pulite e le proporzioni armoniose, si veste dei colori dello spazio in cui è inserito, illuminando giardini e vialetti.

# M

# 90

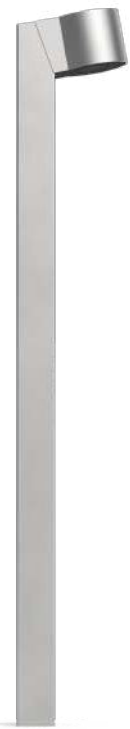

Inox Natural



Inox Graphite



Inox Bronze



STRAL

# M

# 120



Inox Natural



Inox Graphite



Inox Bronze

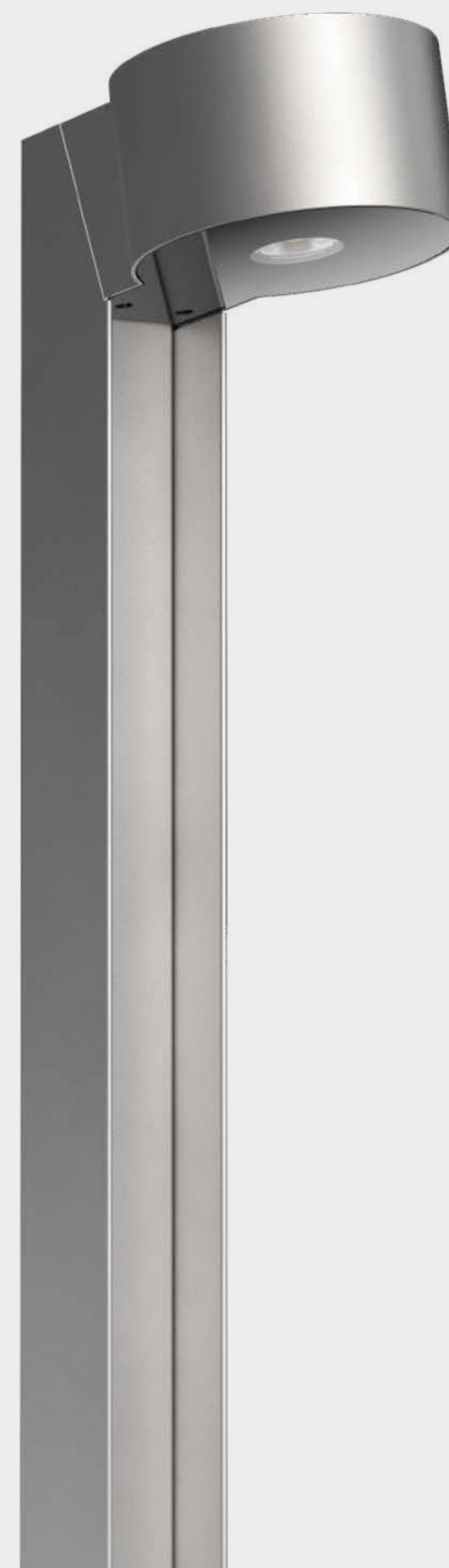

STRAL



EN Bollard available in two heights 60 cm and 90 cm in AISI 316L stainless steel. Pole top available in 90 mm or 120mm diameter versions for different design requirements. 21°, 45° and 65° optics at 2700K, 3000K and 4000K. Flush black silk-screened extra-clear tempered glass, 4 mm thick. Integrated power supply. Flange with anchor bolts for installation in concrete. HCT surface finish available in three variants.

ITA Paletto disponibile in due altezze 60 cm e 90 cm in acciaio inox AISI 316L. Testa palo disponibile nelle versioni con diametro 90 mm o 120mm per diverse esigenze progettuali. Ottiche da 21°, 45° e 65° a 2700K, 3000K e 4000K. Vetro a filo serigrafato nero, temperato extra-chiaro di spessore 4 mm. Alimentatore integrato. Flangia con tirafondi per installazione nel cemento. Finitura superficiale HCT disponibile in tre varianti.

FR Borne disponible en deux hauteurs de 60 et 90 cm, en acier inox AISI 316L. Tête de poteau disponible dans les versions avec diamètre de 90 ou 120mm, selon les exigences de conception. Optiques de 21°, 45° et 65° à 2700K, 3000K et 4000K. Verre affleurant sérigraphié noir, trempé extra-clair de 4 mm d'épaisseur. Alimentation intégrée. Bride avec tirefonds pour installation dans le béton. Finition de surface HCT disponible en trois variantes.

DE Poller erhältlich in zwei Höhen 60 cm und 90 cm aus Edelstahl AISI 316L. Mastaufsatz erhältlich in den Versionen 90 mm oder 120mm für unterschiedliche Designanforderungen. Optiken von 21°, 45° und 65° von 2700K, 3000K und 4000K. Bündiges, extra klares gehärtetes schwarzes Siebdruckglas 4 mm dick. Integriertes Netzteil. Flansch mit Schwellenschrauben zum Einbau in Beton. HCT-Oberflächenbearbeitung in drei Ausführungen erhältlich.

DAN M90

Colour			Emission
2700 K 543 lm	3000 K 550 lm	4000 K 613 lm	
Power 5 W		 Codes Technical details	

IP66 IK08 Accessories p. 238

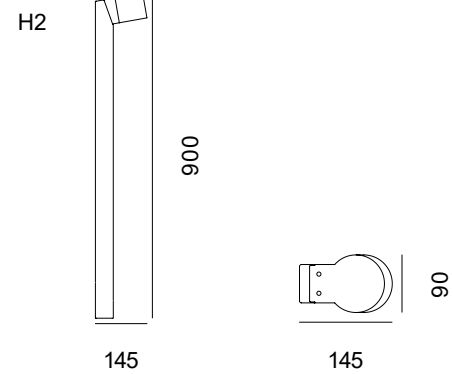
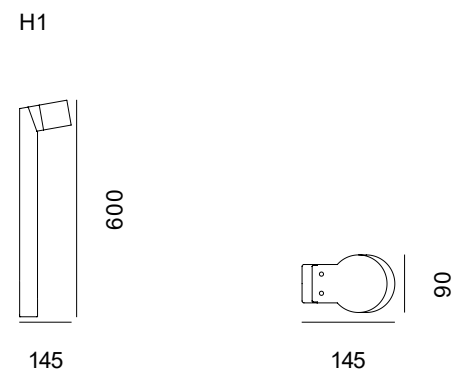

DAN M120

Colour			Emission
2700 K 741 lm	3000 K 750 lm	4000 K 836 lm	
Power 7 W		 Codes Technical details	

IP66 IK08 Accessories p. 238

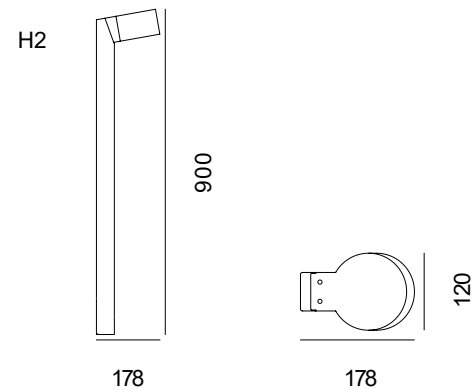
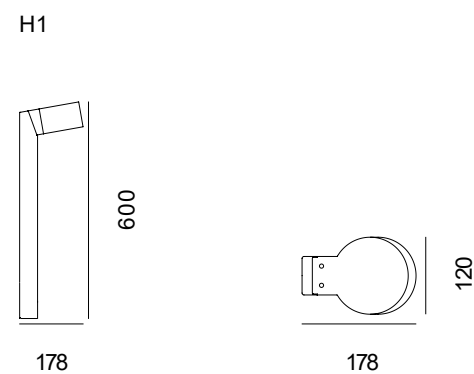

Translations

EN DAN takes inspiration from the Ivory Coast, a very rare statue, jealously hidden inside the huts and exhibited only during important ritual ceremonies. Just as precious is this new bollard with clean lines and harmonious proportions, it is dressed by the surrounded space and colours in which it is inserted, illuminating gardens and paths.

FR C'est la Côte d'Ivoire qui a inspirée DAN, une statue très rare, jalousement cachée à l'intérieur des huttes et exposée uniquement lors d'importants rites. Cette nouvelle borne aux lignes épurées et aux proportions harmonieuses est tout aussi précieuse et se revêt de des couleurs de l'espace où elle est insérée, illuminant jardins et allées.

DE DAN lässt sich von der Elfenbeinküste inspirieren, einer sehr seltenen Statue, die eifersüchtig in den Hütten versteckt und nur während wichtiger ritueller Zeremonien ausgestellt wird. Ebenso edel ist dieser neue Poller mit klaren Linien und harmonischen Proportionen, er ist in den Farben des Raumes, in den er eingefügt wurde, gekleidet und beleuchtet Gärten und Wege.



---

## About

Forse nel buio della sera, guardando di sfuggita ci potrà sembrare una presenza con tratti antropomorfi, una figura dalle dimensioni solide e stabili. È VOLK, l'elemento luminoso bollard più importante a livello di dimensioni della nuova collezione. Per illuminare al meglio ogni spazio esterno con una luce di elevata qualità.

# H

# 50



Inox Natural



Inox Graphite



Inox Bronze



STRAL

EN Bollard available in a single height of 50 cm, made of AISI 316L stainless steel. Pole head with 3 LEDs and 65° optic. Available in 2700K, 3000K and 4000K versions. Flush black silk-screened glass, extra-clear tempered 4 mm thick. Integrated power supply. Flange with anchor bolts for installation in concrete. HCT surface finish available in three variants.

ITA Paletto disponibile in un'unica altezza da 50 cm, realizzato in acciaio inox AISI 316L. Testa palo con 3 LED e ottica a 65°. Disponibile nelle versioni a 2700K, 3000K e 4000K. Vetro a filo serigrafato nero, temperato extra-chiaro di spessore 4 mm. Alimentatore integrato. Flangia con tirafondi per installazione nel cemento. Finitura superficiale HCT disponibile in tre varianti.

FR Borne disponible en une seule hauteur de 50 cm, en acier inox AISI 316L. Tête de poteau avec trois LED et optique à 65°. Disponible en versions 2700K, 3000K et 4000K. Verre affleurant sérigraphié noir, trempé extra-clair de 4 mm d'épaisseur. Alimentation intégrée. Bride avec tirefonds pour installation dans le béton. Finition de surface HCT disponible en trois variantes.

DE Poller verfügbar in einer einzigen Höhe von 50 cm aus Edelstahl AISI 316L. Mastaufsatz mit 3 LEDs und 65° Optik. Erhältlich in den Versionen 2700K, 3000K und 4000K. Bündiges, extra klares gehärtetes schwarzes Siebdruckglas 4 mm dick. Integriertes Netzteil. Flansch mit Schwellenschrauben zum Einbau in Beton. HCT-Oberflächenbearbeitung in drei Ausführungen erhältlich.



VOLK H50

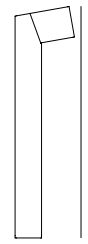

160



135

Colour	Emission	
2700 K 1630 lm	3000 K 1650 lm	4000 K 1840 lm
Power 15 W	 Codes Technical details	
 65°		
<p>IP66   IK08   Accessories p. 239</p>		



Translations

EN Maybe in the evening darkness, looked at in passing, it may seem like a presence with anthropomorphic features, a figure with solid and stable dimensions. It is VOLK, the most important bollard light element in terms of size of the new collection. To better illuminate any outdoor space with high quality light.

FR Dans l'obscurité d'une soirée, en le regardant furtivement, il peut nous sembler une présence aux traits anthropomorphes, une figure aux dimensions solides et stables. C'est VOLK, la borne lumineuse la plus importante en termes de taille de la nouvelle collection. Pour mieux éclairer n'importe quel espace extérieur avec une lumière de haute qualité.

DE Es mag im Dunkeln des Abends im Vorbeigehen wie eine Präsenz mit anthropomorphen Zügen erscheinen, eine Figur mit soliden und stabilen Dimensionen. Es ist VOLK, das größtmäßig wichtigste Pollerleuchtelement der neuen Kollektion. Um jeden Außenbereich mit hochwertigem Licht besser zu beleuchten.

# CAUSEWAY



---

## About

Spostandosi in Irlanda, sulla costa nordorientale, si trova il Selciato del Gigante, nella lista dei Patrimoni dell'umanità UNESCO, un percorso disseminato di colonne basaltiche di origine vulcanica la cui suggestiva conformazione delle rocce ha ispirato antiche leggende che narrano di giganti e di titaniche battaglie. Da questa suggestione nasce la linea di bollard CAUSEWAY.



Inox Natural



Inox Graphite



Inox Bronze





Inox Natural



Inox Graphite



Inox Bronze





Inox Natural



Inox Graphite



Inox Bronze





EN Bollard available in three heights depending on the selected pole head, in AISI 316L stainless steel. Pole top available in versions with one, two or three LEDs with frontal emission. 21°, 45° and 65° optics at 2700K, 3000K and 4000K. Flush black silk-screened extra-clear tempered glass, 4 mm thick. Integrated power supply. Flange with anchor bolts for installation in concrete. HCT surface finish available in three variants.

ITA Paletto disponibile in tre altezze a seconda della testa palo selezionata, in acciaio inox AISI 316L. Testa palo disponibile nelle versioni a uno, due o tre LED con emissione frontale. Ottiche da 21°, 45° e 65° da 2700K, 3000K e 4000K. Vetro a filo serigrafato nero, temperato extra-chiaro di spessore 4 mm. Alimentatore integrato. Flangia con tirafondi per installazione nel cemento. Finitura superficiale HCT disponibile in tre varianti.

FR Borne disponible en trois hauteurs selon la tête de poteau choisie, en acier inox AISI 316L. Tête de poteau disponible dans les versions à une, deux ou trois LED à émission frontale. Optiques de 21°, 45° et 65° à 2700K, 3000K et 4000K. Verre affleurant sérigraphié noir, trempé extra-clair de 4 mm d'épaisseur. Alimentation intégrée. Bride avec tirefonds pour installation dans le béton. Finition de surface HCT disponible en trois variantes.

DE Poller je nach gewähltem Mastaufsatz in drei Höhen erhältlich, aus Edelstahl AISI 316L. Mastaufsatz erhältlich in Versionen mit einer, zwei oder drei LEDs mit Frontausstrahlung. Optiken von 21°, 45° und 65° von 2700K, 3000K und 4000K. Bündiges, extra klares gehärtetes schwarzes Siebdruckglas 4 mm dick. Integriertes Netzteil. Flansch mit Schwellenschrauben zum Einbau in Beton. HCT-Oberflächenbearbeitung in drei Ausführungen erhältlich.

#### CAUSEWAY M01

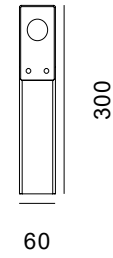
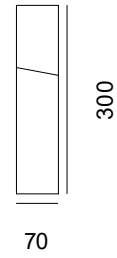

Colour	
2700 K 543 lm	3000 K 550 lm
4000 K 613 lm	

Emission	
21°	
45°	
65°	

Power 5 W		Codes Technical details
--------------	--	----------------------------

IP66 IK08 Accessories p. 239

#### CAUSEWAY M02

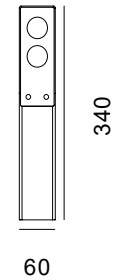
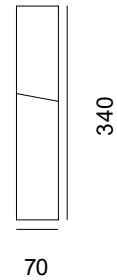

Colour	
2700 K 1087 lm	3000 K 1100 lm
4000 K 1227 lm	

Emission	
21°	
45°	
65°	

Power 10 W		Codes Technical details
---------------	--	----------------------------

IP66 IK08 Accessories p. 239

#### CAUSEWAY M03

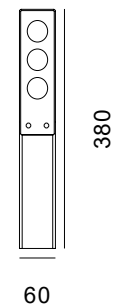
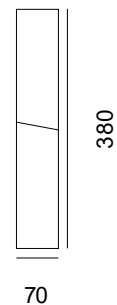

Colour	
2700 K 1630 lm	3000 K 1650 lm
4000 K 1840 lm	

Emission	
21°	
45°	
65°	

Power 15 W		Codes Technical details
---------------	--	----------------------------

IP66 IK08 Accessories p. 239



#### Translations

EN Moving to Ireland, on the north-east coast, we find the Giant's Causeway, in the UNESCO World Heritage Sites list, a path strewn with basalt columns of volcanic origin whose evocative shape of the rocks has inspired ancient legends of giants and titans battles. The CAUSEWAY bollard line was born from this suggestion.

FR Si vous allez en Irlande, vous trouverez sur la côte nord-est, la Chaussée des Géants. Ce promontoire parsemé de colonnes de basalte d'origine volcanique est inscrit sur la liste des sites du patrimoine mondial de l'UNESCO et la forme évocatrice de ses rochers a inspiré d'anciennes légendes qui parlent de géants et de batailles de titans. La ligne de bornes CAUSEWAY a tiré son inspiration de ce lieu enchanteur.

DE An der Nordostküste Irlands befindet sich die Straße der Riesen (Giant's Causeway), die in die Liste des UNESCO-Weltkulturerbes aufgenommen wurde, ein Weg, der mit Basaltsäulen vulkanischen Ursprungs übersät ist, deren eindrucksvolle Form der Felsen alte Legenden inspiriert hat, die von Riesen und Titanenschlachten erzählen. Aus diesem Vorschlag entstand die Pollerlinie CAUSEWAY.



---

## About

Un sistema componibile che accompagna l'estro progettuale, lasciando libertà di espressione e di movimento. Una sintesi della collezione ben espressa da DIAL, nato per soddisfare le situazioni illuminotecniche più complesse e per dar voce alla fantasia di chi lo sceglie.

# H

# 2500 / 3000

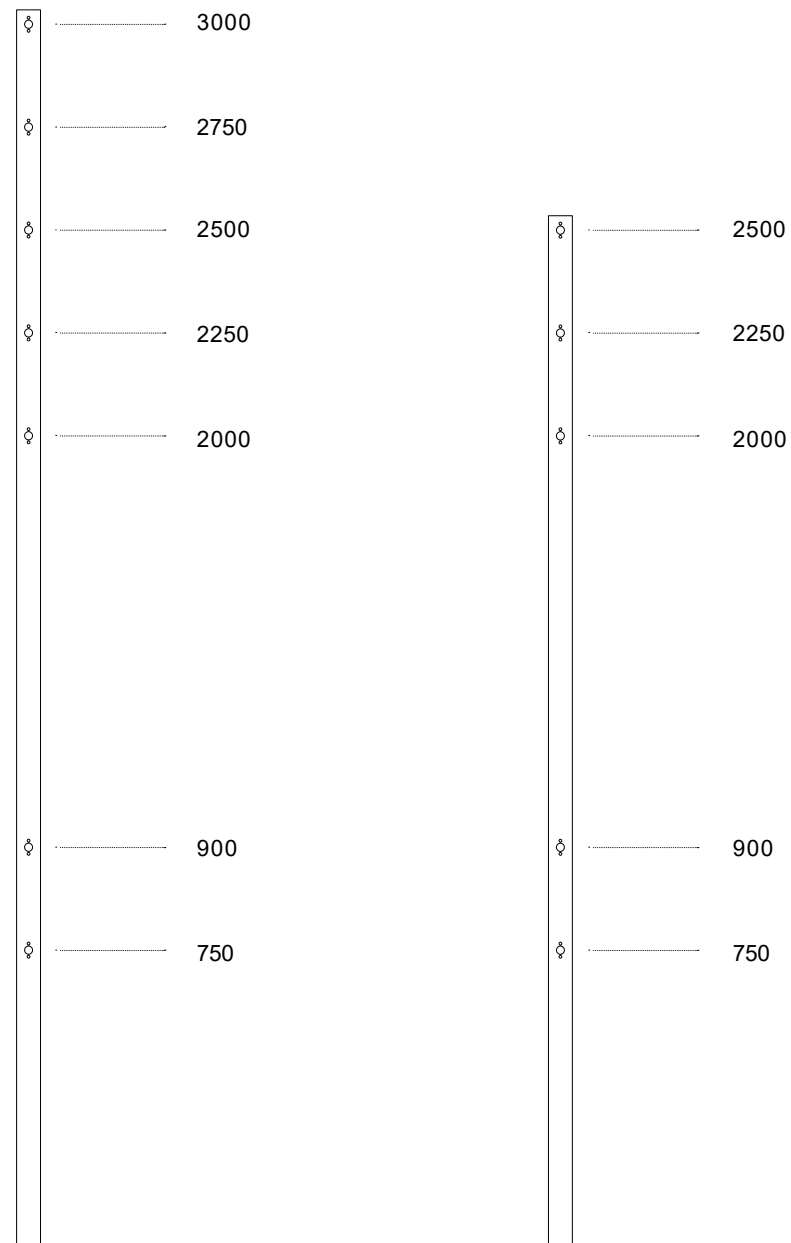

DYKE

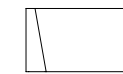

M01



M02

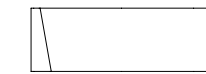

M03

DYKE ROTO

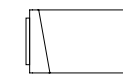

M01



M02



M03

DYKE FLEX

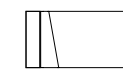

M01

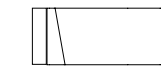

M02

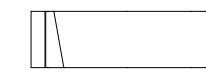

M03

EN Fully configurable on request, choose from the many options indicated in the drawing.

ITA Foratura configurabile a richiesta tra le opzioni indicate a disegno.

FR Forage configurable sur demande entre les options indiquées au dessin.

DE Auf anfrage konfigurierbare bohrung nach den in der zeichnung angegebenen optionen.



01



02



03

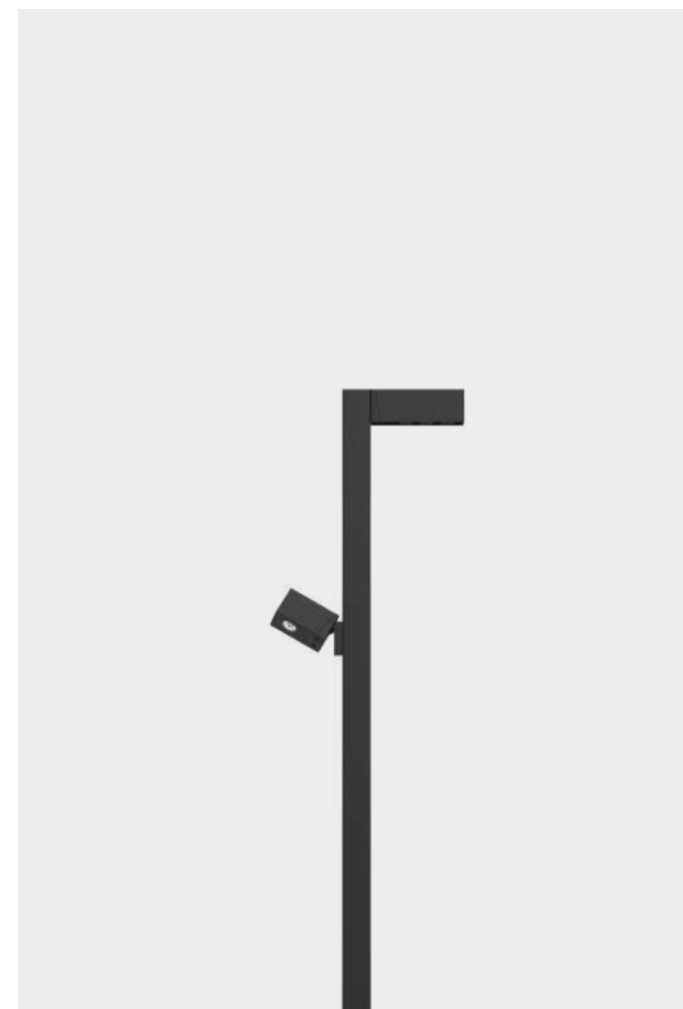

04

- 01 2 x DYKEM03
- 02 3 x DYKEROTO M02
- 03 4 x DYKE FLEX M03
- 04 DYKEM03 + DYKEFLEX M01

EN System configurable with models DYKE, DYKE FLEX, DYKE ROTO, available in two heights 250 cm and 300 cm made of AISI 316L stainless steel. Pole's dimensions 6x6 cm with holes in a predefined position. Flange with anchor bolts for installation in concrete. Surface finishes in matt RAL9004 painting and satin stainless steel.

ITA Sistema configurabile con gli apparecchi DYKE, DYKE FLEX, DYKE ROTO, disponibile in due altezze 250 cm e 300 cm realizzato in acciaio inox AISI 316L. Dimensioni 6x6 cm del palo con fori in posizione predefinita. Flangia con tirafondi per installazione nel cemento. Verniciatura superficiale RAL9004 opaco e finitura in acciaio inox satinato.

FR Système configurable avec les luminaires DYKE, DYKE FLEX, DYKEROTO, disponible en deux hauteurs 250 cm et 300 cm en acier inox AISI 316L. Dimensions du poteau 60x60 avec trous prédéfinis. Bride avec tirefonds pour installation dans le béton. Peinture de surface mate RAL9004 et finition en acier inox satiné.

DE System konfigurierbar mit den Leuchten DYKE, DYKE FLEX, DYKEROTO, erhältlich in zwei Höhen 250 cm und 300 cm aus Edelstahl AISI 316L. Abmessungen 60x60 des Mastes mit Bohrungen in einer vordefinierten Position. Flansch mit Schwellenschrauben zum Einbau in Beton. Oberflächenlackierung RAL9004 matt und Endbearbeitung aus satiniertem Edelstahl.

H2500

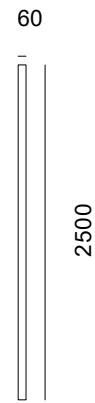

With flange



Codes  
Technical details

Works with  
DYKE  
DYKE ROTO  
DYKE FLEX

Accessories p. 239

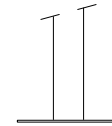
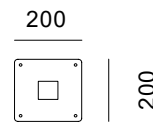

Buried



Codes  
Technical details

Works with  
DYKE  
DYKE ROTO  
DYKE FLEX

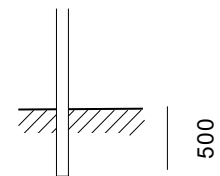

H3000

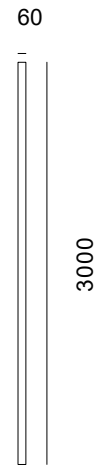

With flange



Codes  
Technical details

Works with  
DYKE  
DYKE ROTO  
DYKE FLEX

Accessories p. 239

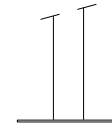
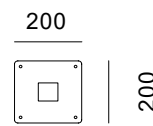

Buried



Codes  
Technical details

Works with  
DYKE  
DYKE ROTO  
DYKE FLEX

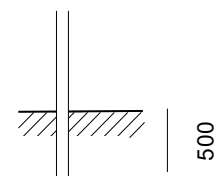

Translations

EN A modular system that accompanies the freedom of expression and movement.

A synthesis of the collection, well expressed by DIAL, created to satisfy the most complex lighting situations and to give voice to the imagination of those who choose it.

FR Un système modulaire qui inspire la conception, laissant la liberté d'expression et de mouvement. Une synthèse de la collection bien exprimée par DIAL, créée pour apporter une solution satisfaisante aux situations d'éclairage les plus complexes et pour permettre de s'exprimer à l'imagination de ceux qui la choisissent.

DE Ein modulares System, das die Design-Inspiration begleitet und Freiheit für Ausdruck und Bewegung lässt. Eine Synthese der Kollektion, die von DIAL gut zum Ausdruck gebracht wurde, um den komplexesten Beleuchtungssituationen gerecht zu werden und der Fantasie derjenigen eine Stimme zu geben, die sie wählen.

# MOON



---

## About

La morbidezza della luce lunare evocata da MOON. La sua linea estetica austera è destinata a durare nel tempo, tanto quanto la sua struttura in acciaio inox AISI 316L. Lo ritroviamo nella nuova collezione per continuare a garantire uno standard elevato nei materiali e nelle performance illuminotecniche nei contesti che lo richiedono, come pontili, zone lungomare, parcheggi e piazze.

# N

# 200



Inox Satin



Inox RAL9004



STRAL

# N

# 270



Inox Satin



Inox RAL9004



STRAL



EN Integrated pole-mounted system for street furniture, pole-top available with 3000K and 4000K asymmetrical and street optics and poles with heights from 350 cm to 600 cm both made of AISI 316L stainless steel. Pole diameter 102 mm. Fixing system through a flange with anchor bolts available for installation in concrete or in the version to be buried. Surface in matt RAL9004 painting and satin stainless steel finish.

ITA Sistema integrato su palo per arredo urbano, testa-palo disponibile con ottiche asimmetriche e stradali da 3000K e 4000K e pali con altezza da 350 cm a 600 cm realizzati entrambi in acciaio inox AISI 316L. Diametro del palo 102 mm. Disponibile sistema di fissaggio tramite flangia con tirafondi per installazione nel cemento o nella versione da interrare. Verniciatura superficiale RAL9004 opaco e finitura in acciaio inox satinato.

FR Système intégré sur poteau pour aménagement urbain, tête de poteau disponible avec optiques asymétriques et de rue de 3000K et 4000K et poteaux avec des hauteurs de 350 cm à 600 cm, tous deux en acier inox AISI 316L. Diamètre du poteau 102 mm. Système de fixation au moyen d'une bride avec tirefonds disponibles pour l'installation dans le béton ou dans la version à enterrer. Peinture de surface mate RAL9004 et finition en acier inox satiné.

DE Integriertes Mastsystem für städtische Ausstattung, Mastaufsatz erhältlich mit 3000K und 4000K asymmetrischer und Straßenoptik sowie Masten mit Höhen von 350 cm bis 600 cm, beide aus Edelstahl AISI 316L. Mastdurchmesser 102 mm. Befestigungssystem mit Flansch mit Schwellenschrauben für den Einbau in Beton oder in unterirdischer Ausführung erhältlich. Oberflächenlackierung RAL 9004 matt und Endbearbeitung aus satiniertem Edelstahl.

MOON N200

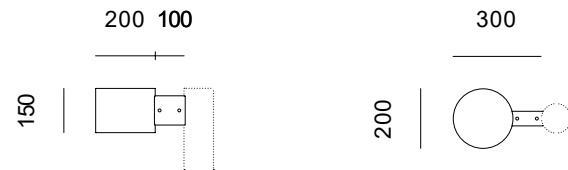

Colour	3000 K 3000 lm	4000 K 3345 lm	Emission	Street
Power	24 W		Asymmetrical	
			Codes Technical details	
IP66		IK08		

MOON N270



Colour	3000 K 4500 lm	4000 K 5018 lm	Emission	Street
Power	32 W		Asymmetrical	
			Codes Technical details	
IP66		IK08		

Colour	3000 K 6000 lm	4000 K 6690 lm	Emission	Street
Power	48 W		Asymmetrical	
			Codes Technical details	
IP66		IK08		

Composition

Single

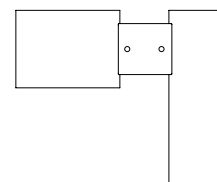

Double

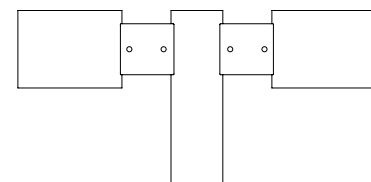

Pole with flange

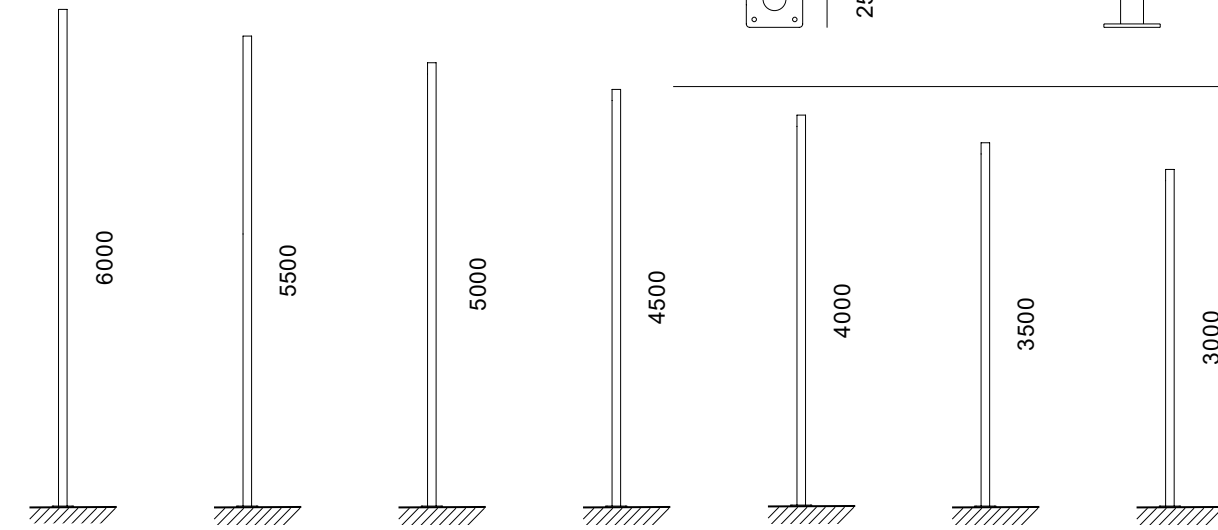

With flange Codes Technical details Works with MOON 200 MOON 270



Pole to be buried

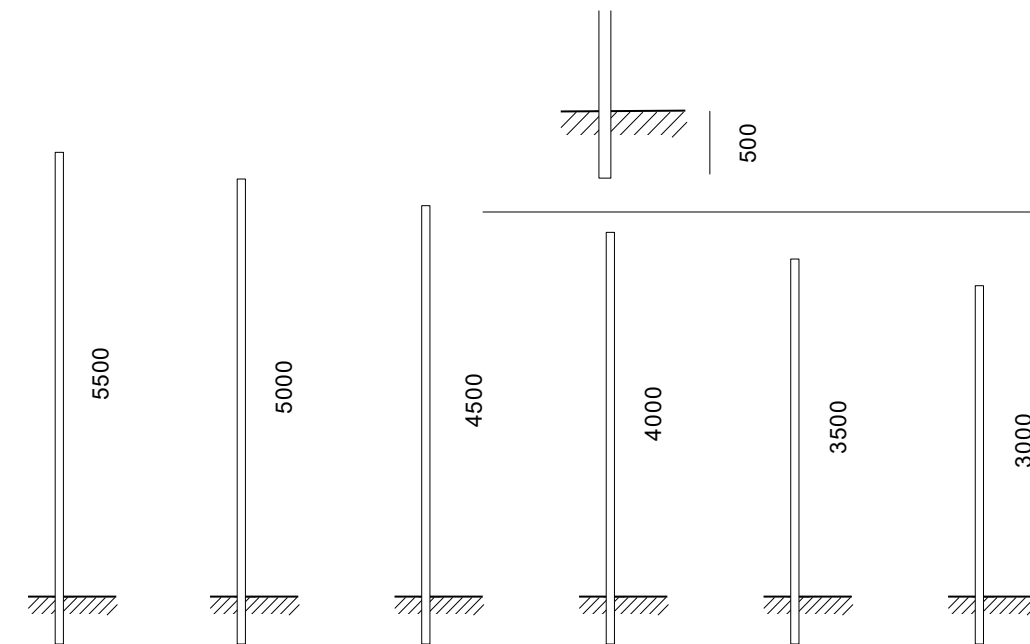

Buried Codes Technical details Works with MOON 200 MOON 270

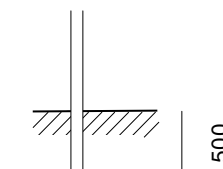

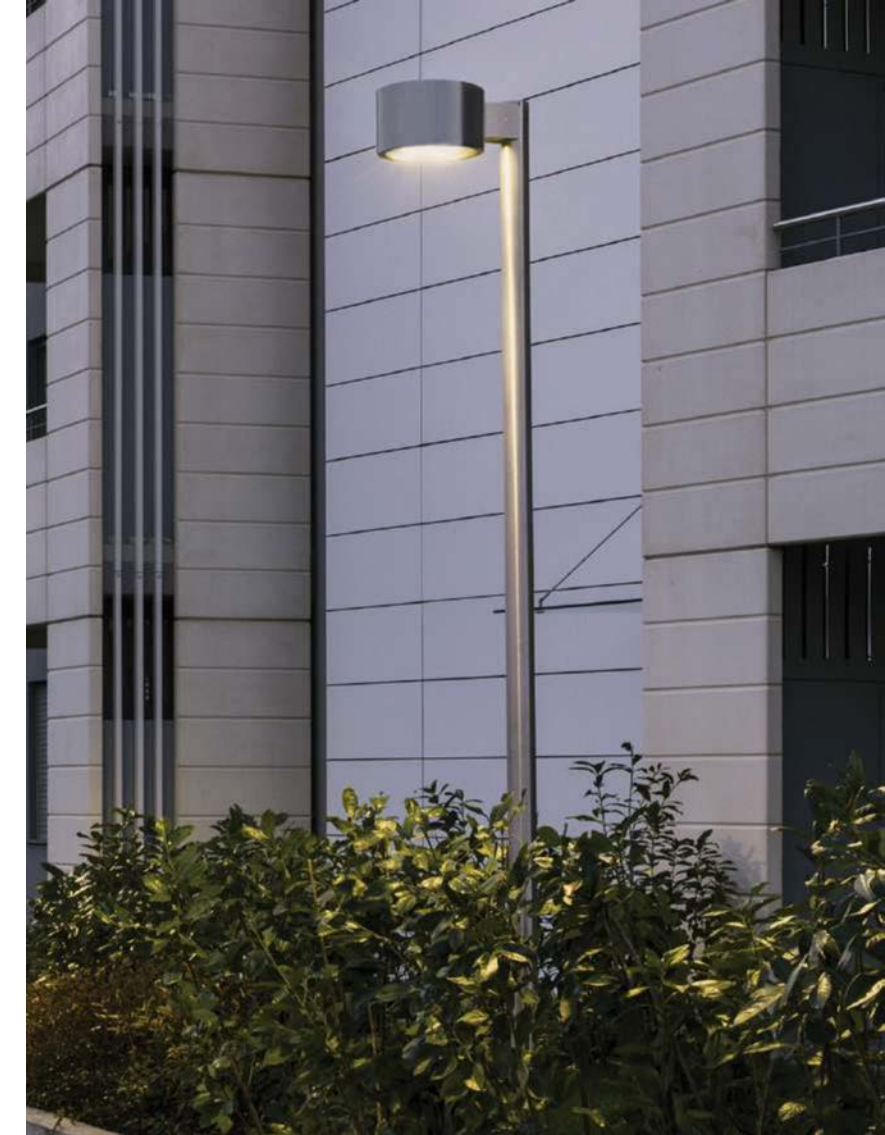

---

Translations

EN The softness of the moonlight, evoked by MOON. Its austere aesthetic line is destined to last over time, as much as its structure in AISI 316L stainless steel. We find it in the new collection to continue to guarantee a high standard in materials and lighting performance, in contexts that require it, such as piers, waterfront areas, car parks and squares.

FR La douceur du clair de lune évoquée par MOON. Sa ligne esthétique austère est vouée à durer dans le temps, tout comme sa structure en acier inox AISI 316L. Nous le trouvons dans la nouvelle collection pour continuer à garantir un niveau élevé dans les matériaux et les performances d'éclairage dans des contextes qui l'exigent, tels que les jetées, les fronts de mer, les parkings et les places.

DE Die Weichheit des Mondlichts wird von MOON hervorgehoben. Seine strenge ästhetische Linie ist ebenso wie seine Struktur aus Edelstahl AISI 316L für eine lange Lebensdauer bestimmt. Wir finden es in der neuen Kollektion, um weiter einen hohen Standard an Materialien und Lichtleistung in Kontexten zu garantieren, die dies erfordern, wie zum Beispiel Stege, Uferbereichen, Parkplätzen und Plätzen.

# SHELFIE



---

## About

Geometrie squadrate e nette si intersecano formando un volume solido e rassicurante. SHELFIE con il suo rigore formale, abbraccia la coerenza stilistica di tutta la collezione per consentire il completamento dei progetti più complessi. Scelto per l'arredo urbano curato con materiali di qualità e ottiche professionali.

# T

# 700

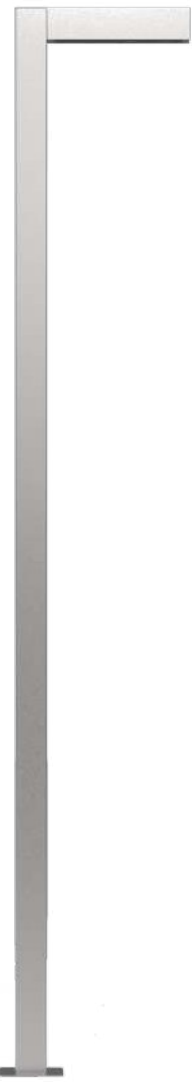

Inox Satin



Inox RAL9004



STRAL

EN Integrated pole-mounted system for street furniture, pole-top available with 3000K and 4000K asymmetrical and street optics and poles with heights from 350 cm to 600 cm both made of AISI 316L stainless steel. Pole's section 150x150mm. Fixing system through a flange with anchor bolts available for installation in concrete or in the version to be buried. Surface in matt RAL9004 painting and satin stainless steel finish.

ITA Sistema integrato su palo per arredo urbano, testa-palo disponibile con ottiche asimmetriche e stradali da 3000K e 4000K e pali con altezza da 350 cm a 600 cm realizzati entrambi in acciaio inox AISI 316L. Sezione del palo 150x150 mm. Disponibile sistema di fissaggio tramite flangia con tirafondi per installazione nel cemento o nella versione da interrare. Verniciatura superficiale RAL9004 opaco e finitura in acciaio inox satinato.

FR Système intégré sur poteau pour aménagement urbain, tête de poteau disponible avec optiques asymétriques et de rue de 3000K et 4000K et poteaux avec des hauteurs de 350 cm à 600 cm, tous deux en acier inox AISI 316L. Section du poteau 150x150mm. Système de fixation au moyen d'une bride avec tirefonds disponibles pour l'installation dans le béton ou dans la version à enterrer. Peinture de surface mate RAL9004 et finition en acier inox satiné.

DE Integriertes Mastsystem für städtische Ausstattung, Mastaufsatz erhältlich mit 3000K und 4000K asymmetrischer und Straßenoptik sowie Masten mit Höhen von 350 cm bis 600 cm, beide aus Edelstahl AISI 316L. Mastquerschnitt 150x150 mm. Befestigungssystem mit Flansch mit Schwellenschrauben für den Einbau in Beton oder in unterirdischer Ausführung erhältlich. Oberflächenlackierung RAL 9004 matt und Endbearbeitung aus satiniertem Edelstahl.

SHELFIE T700

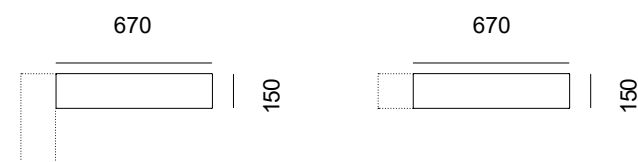

ColoUr	3000 K 3450 lm	4000 K 4388 lm	Emission Street
Power 24 W			Asymmetrical
Codes Technical details			

ColUor	3000 K 4600 lm	4000 K 5850 lm	Emission Street
Power 32 W			Asymmetrical
Codes Technical details			

IP66 IK08

Composition

Single



Double

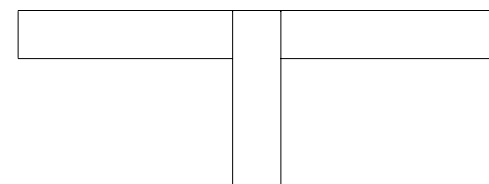

Pole with flange

With flange Codes Technical details Works with SHELFIE

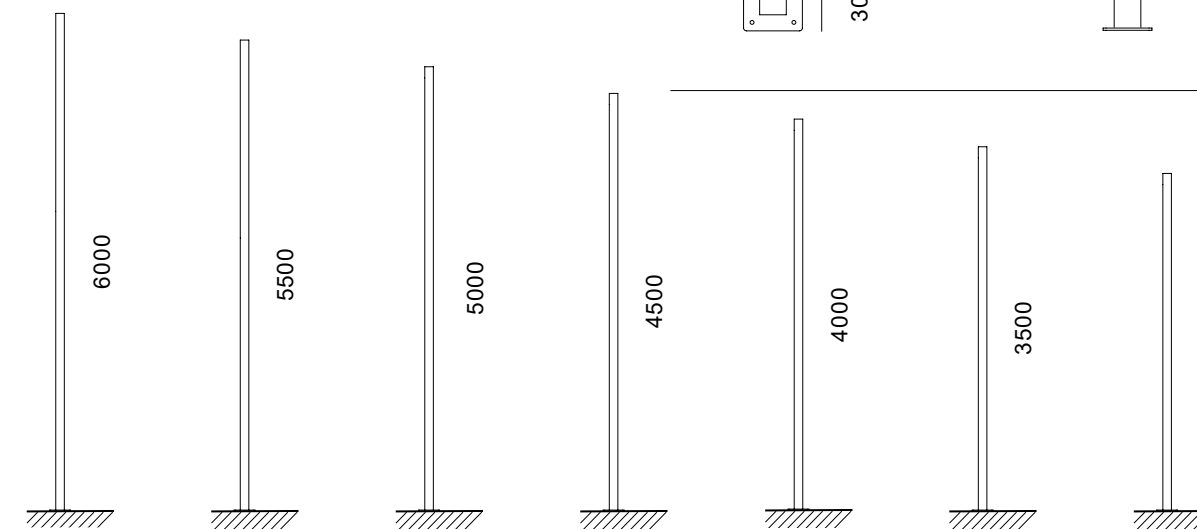

Pole to be buried

Buried Codes Technical details Works with SHELFIE

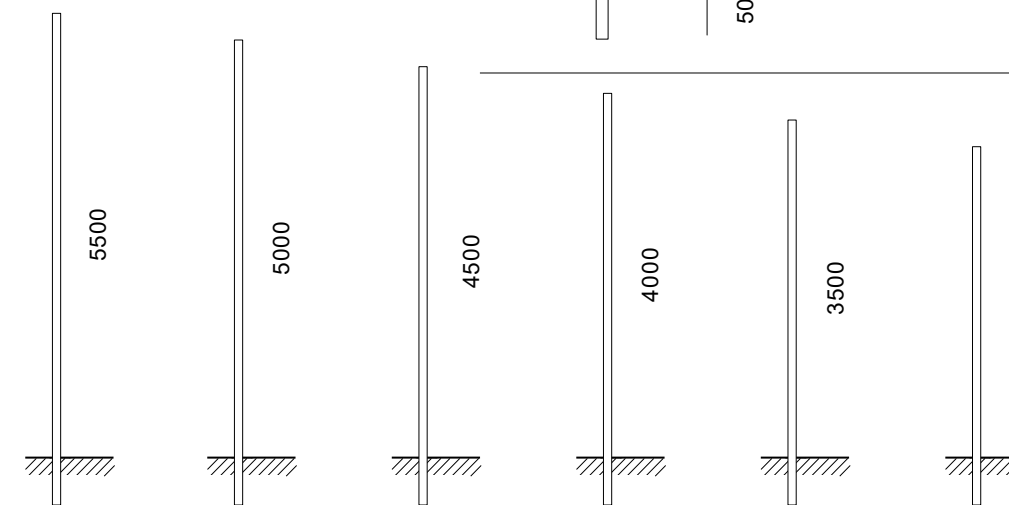
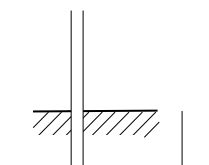



---

Translations

EN Square and clear-cut geometries intersect to form a solid and reassuring volume. SHELFIE with its formal rigour, embraces the stylistic coherence of the entire collection to allow most complex projects completion. Chosen for street furniture made with quality materials and professional optics.

FR Des géométries carrées et précises se croisent pour former un volume solide et rassurant. SHELFIE avec sa rigueur formelle s'unit à la cohérence stylistique de l'ensemble de la collection pour permettre la réalisation des projets les plus complexes. Choisi pour un aménagement urbain soigné avec des matériaux de qualité et des optiques professionnelles.

DE Quadratische und klare Geometrien kreuzen sich und bilden ein solides und beruhigendes Volumen. SHELFIE greift mit seiner formalen Strenge die stilistische Kohärenz der gesamten Kollektion auf, um auch komplexeste Projekte realisieren zu können. Ausgewählt für städtische Ausstattung aus hochwertigen Materialien und professioneller Optik.

GAME CASING

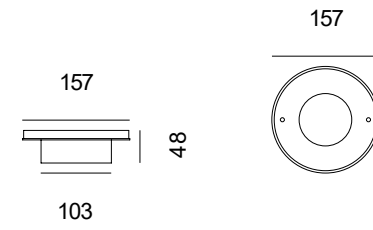

OLY N110 CASING

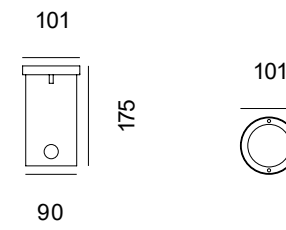

OLY N180 CASING

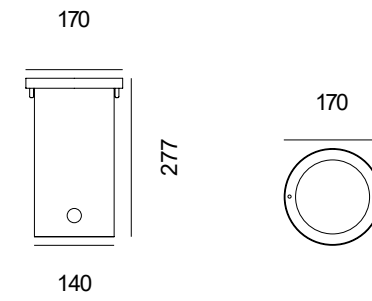

OLY N240 CASING

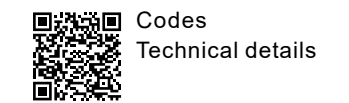
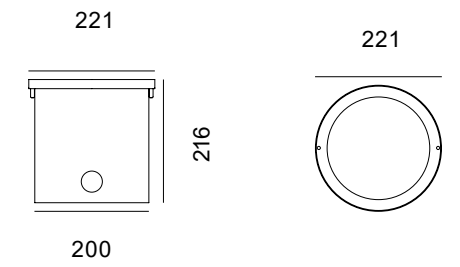

OTTAGONO CASING

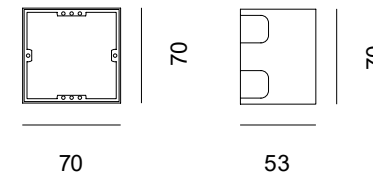

STARLIGHT CASING

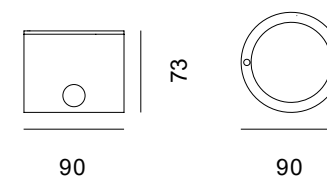

KANDOVAN H130 CASING



KANDOVAN H270 CASING

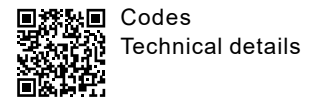
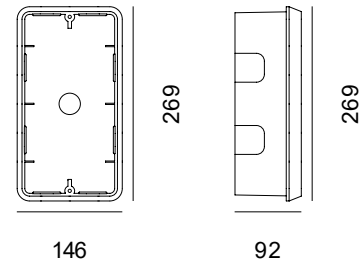

BASE CASING

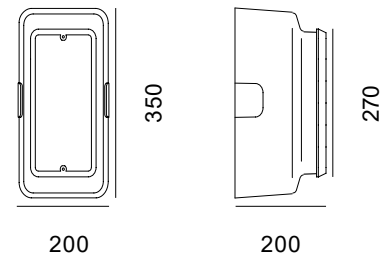

DRIVER8W 350MA 3-36V IP65

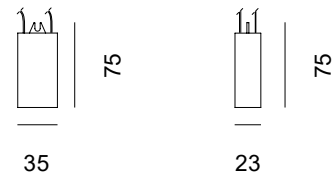

DRIVER9W 700MA 3-21V IP65

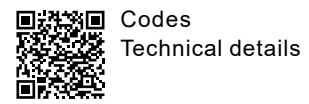
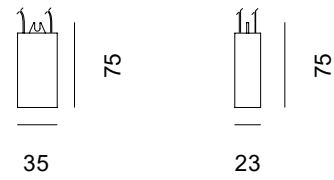

FLANGE WITH 4 ANCHOR BOLTS FOR KRAN AND DAN

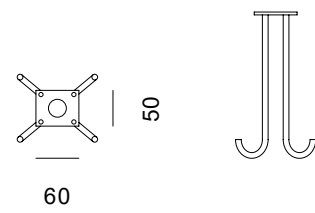

FLANGE WITH 4 ANCHOR BOLTS FOR VOLK

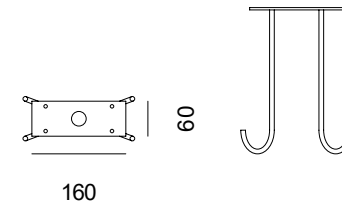

FLANGE WITH 4 ANCHOR BOLTS FOR CAUSEWAY

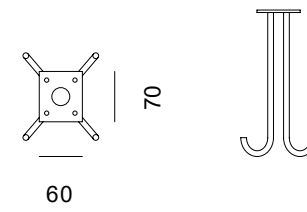

ANCHOR BOLTS FOR DIAL

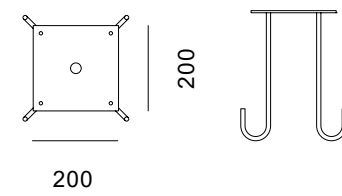



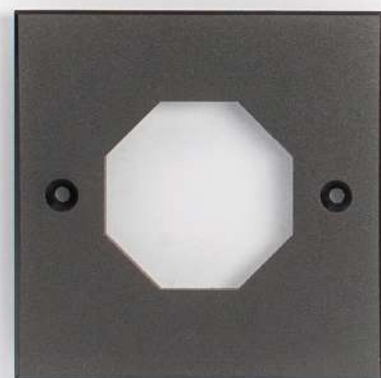

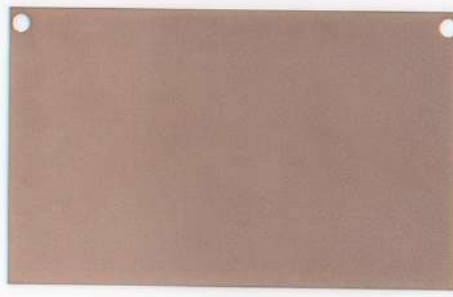
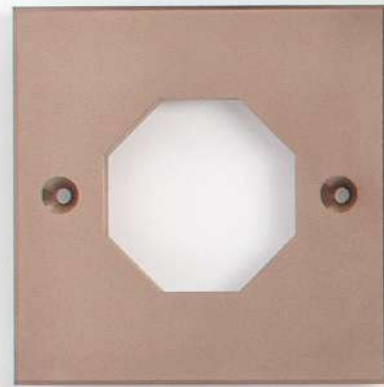
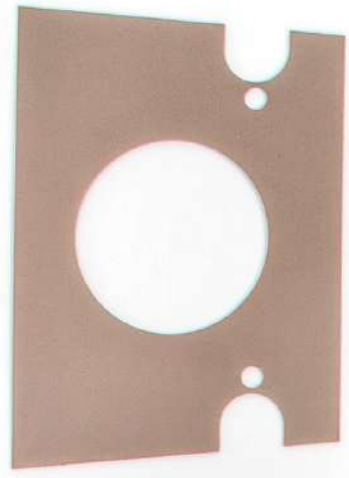

## Palazzoli

STRAL è il marchio d'illuminazione architettuale del Gruppo Palazzoli. La storia di Palazzoli, nel settore della produzione di materiale elettrico, ha inizio tra la fine dell'800 e l'inizio del '900 quando Federico Palazzoli diede vita alla sua azienda spinto da idee altamente innovative per l'epoca. Le stesse idee che alimentano lo sviluppo costante della Palazzoli oggi. Dall'avvio al primo stabilimento per la produzione di materiale elettrico e illuminotecnico dedicato all'industria, al settore atex, alle infrastrutture e al navale, Palazzoli continua a rappresentare uno spaccato illustre della storia industriale italiana, oggi apprezzata in tutto il mondo. Il Gruppo Palazzoli si pone tra i grandi protagonisti internazionali della produzione di sistemi elettrici e di illuminazione.

Laboratorio,  
Ricerca  
& Sviluppo

Tutti i test sugli apparecchi illuminanti vengono eseguiti nel laboratorio interno certificato. Ricerca, progettazione e sviluppo d'avanguardia con Cad e software di simulazione ottica e illuminotecnica con tecnici altamente formati. Il laboratorio interno effettua prove di omologazione di tutti i prodotti che successivamente vengono certificati da enti accreditati. Palazzoli ha ottenuto il riconoscimento CTF2 (Customer Testing Facilities) per poter effettuare nel proprio Laboratorio le prove sui prodotti elettrici. Le fotometrie sono testate direttamente in fabbrica. Il laboratorio Palazzoli è dotato di apparecchiature adeguate compreso il gonio-fotometro a specchio rotante corredato di spettro-radiometro per la misurazione della qualità della luce (CCT, CRI e coordinate cromatiche). Questo e altri strumenti per test quali: IP, IK, nebbia salina, umidità, isolamento, sfera integratrice, spettro radiometro, riscaldamento, durata, ecc. sono presenti all'interno della fabbrica. Il Reparto per l'assemblaggio dei nostri apparecchi è protetto con materiale antistatico e con abilitazione all'accesso attraverso una stazione di test. Ogni prodotto è sottoposto individualmente a test elettrici e ottici.

Garanzia e  
trattamenti  
superficiali

Garantiamo fino a 5 anni i nostri apparecchi sulla parte elettrica ed elettronica e 10 anni sul materiale contro la corrosione passante. Gli apparecchi soggetti a verniciatura vengono trattati con una speciale vernice a polvere in poliestere ultra resistente. Le innovative finiture HCT (Hard Coating Treatment) della nuova collezione: Inox Graphite - Inox Bronze - Inox Natural garantiscono un'elevata resistenza superficiale alla corrosione e agli agenti atmosferici oltre a rendere i prodotti anti impronta ed anti macchia.

EN

**GROUP - HISTORY**

STRAL is the architectural lighting brand of the Palazzoli Group. The history of Palazzoli, in the electrical material production sector, begins between the end of the 19th and the beginning of the 20th century when Federico Palazzoli gave life to his company driven by highly innovative ideas for the time. The same ideas that today fuel the constant development of Palazzoli. From the start of the first plant for the production of electrical and lighting equipment dedicated to industry, the atex sector, infrastructure and the naval sector, Palazzoli continues to represent an illustrious cross-section of Italian industrial history, today appreciated all over the world. The Palazzoli Group is one of the major international players in the production of electrical and lighting systems.

**LABORATORY, RESEARCH & DEVELOPMENT**

All tests on lighting fixtures are carried out in the certified internal laboratory. Cutting-edge research, design, development with Cad, optical and lighting simulation software guaranteed by highly trained technicians. The internal laboratory carries out homologation tests on all products which are subsequently certified by accredited bodies. Palazzoli has obtained the CTF2 (Customer Testing Facilities) recognition to be able to carry out tests on electrical products in its own laboratory. The photometries are tested directly in the factory. The Palazzoli laboratory is equipped with adequate tools including the rotating mirror goniophotometer with a spectro-radiometer for measuring the quality of light (CCT, CRI and chromatic coordinates). This and other test tools such as: IP, IK, salt spray, humidity, insulation, integrating sphere, radiometer spectrum, heating, durability, etc. are available inside the factory. The assembly department of our devices is protected with antistatic material and only with access authorization through a test station. Each product is individually subjected to electrical and optical tests.

**WARRANTY & SURFACE TREATMENTS**

We guarantee our items up to 5 years on the electrical and electronic parts and 10 years on the material against corrosion-through. The devices subject to painting are treated with a special ultra-resistant polyester powder paint. The innovative HCT (Hard Coating Treatment) finishes of the new collection: Inox Graphite - Inox Bronze - Inox Natural guarantee high surface resistance to corrosion and atmospheric agents as well as making the products anti-fingerprint and anti-stain.

FR

**LE GROUPE - SON HISTOIRE**

STRAL est la marque d'éclairage architectural du groupe italien Palazzoli. L'histoire de Palazzoli, dans le secteur de la production de matériel électrique, commence entre la fin du 19e et le début du 20e siècle lorsque Federico Palazzoli, animé par des idées très innovantes pour l'époque, a créé son entreprise. Ce sont ces mêmes idées qui aujourd'hui encore sont le moteur constant du développement de Palazzoli. Du démarrage à la première usine de production de matériel électrique et d'éclairage dédiée à l'industrie, au secteur Atex, aux infrastructures et au secteur naval, Palazzoli continue de représenter un important chapitre de l'histoire industrielle italienne. L'entreprise est aujourd'hui une référence reconnue dans le monde entier. Le Groupe Palazzoli est l'un des principaux acteurs internationaux dans la production de systèmes électriques et d'éclairage.

**LABORATOIRE, RECHERCHE ET DÉVELOPPEMENT**

Tous les tests sur les luminaires sont effectués dans notre laboratoire interne et certifié. Recherche, conception et développement de pointe avec des logiciels de CAO et de simulation optique et d'éclairage avec des techniciens hautement qualifiés. Notre laboratoire interne effectue des essais d'homologation sur tous les produits qui sont ensuite certifiés par des organismes agréés. Palazzoli a obtenu la reconnaissance CTF 2 (Customer Testing Facilities) pour pouvoir tester ses propres produits électriques au sein de son laboratoire. Les photométries sont testées directement en usine. Le laboratoire Palazzoli est équipé d'équipements appropriés dont le goniophotomètre avec miroir rotatif et un spectro-radiomètre pour mesurer la qualité de la lumière (CCT, CRI et coordonnées chromatiques). Tous ces instruments ainsi que d'autres instruments pour les tests IP, IK, brouillard salin, humidité, isolation, sphère d'intégration, spectre radiométrique, chauffage, durabilité sont présents à l'intérieur de l'usine. Le département pour l'assemblage de nos luminaires est protégé avec du matériel antistatique et dispose d'une autorisation d'accès à travers une station de test. Chaque produit est soumis individuellement à des tests électriques et optiques.

**GARANTIE et TRAITEMENTS DE SURFACE**

Les parties électriques et électroniques de nos luminaires sont garanties jusqu'à 5 ans tandis que le matériel contre la corrosion due à la rouille est garanti 10 ans. Les luminaires peints sont traités avec une peinture

spéciale à base de poudre en polyester ultrarésistante. Les finitions HCT (Hard Coating Treatment) innovantes de la nouvelle collection : Inox Graphite - Inox Bronze - Inox Natural garantissent une résistance élevée de la surface à la corrosion et aux agents atmosphériques tout en rendant les produits anti-empreintes et antitaches.

DE

**UNTERNEHMENSGRUPPE – GESCHICHTE**

STRAL ist die Marke der architektonischen Beleuchtung der Palazzoli-Gruppe. Die Geschichte von Palazzoli im Bereich der Elektromaterialherstellung beginnt zwischen dem Ende des 19. Jahrhunderts und dem Anfang des 20. Jahrhunderts, als Federico Palazzoli sein Unternehmen gründete, angetrieben von hochinnovativen Ideen für diese Zeit. Dieselben Ideen, die heute die ständige Entwicklung von Palazzoli antreiben. Seit der Inbetriebnahme des ersten Werks zur Herstellung von Elektro- und Beleuchtungsgeräten für die Industrie, den Atex-Sektor, die Infrastruktur und den Marinesektor zeigt Palazzoli einen illustren Querschnitt der italienischen Industriegeschichte, der heute auf der ganzen Welt geschätzt wird. Die Palazzoli-Gruppe ist einer der bedeutendsten internationalen Protagonisten bei der Produktion von Elektro- und Beleuchtungssystemen.

**LABOR, FORSCHUNG & ENTWICKLUNG**

Alle Prüfungen an Beleuchtungskörpern werden im zertifizierten internen Labor durchgeführt. Innovative Forschung, Design und Entwicklung mit Cad und Optik- und Lichtsimulationssoftware mit hochqualifizierten Technikern. Das interne Labor führt an allen Produkten Homologationsprüfungen durch, die anschließend von akkreditierten Stellen zertifiziert werden. Palazzoli hat die Anerkennung CTF 2 (Customer Testing Facilities) erhalten, um Prüfungen an elektrischen Produkten im eigenen Labor durchführen zu können. Die Photometrien werden direkt im Werk geprüft. Das Labor von Palazzoli ist mit angemessener Ausrüstung ausgestattet, einschließlich des Drehspiegel-Goniophotometers, das mit einem Spektroradiometer zur Messung der Lichtqualität (CCT, CRI und chromatische Koordinaten) ausgestattet ist. Dieses und andere Instrumente für Tests wie: IP, IK, Salznebel, Feuchtigkeit, Isolierung, Ulbrichtsche Kugel, Radiometerspektrum, Erwärmung, Dauer usw. sind im Werk vorhanden. Die Abteilung für die Montage unserer Geräte ist mit antistatischem Material und mit Zugangsberechtigung durch eine Prüfstation geschützt. Jedes Produkt wird einzeln elektrischen und optischen Prüfungen unterzogen.

**GARANTIE und OBERFLÄCHENBEHANDLUNGEN**

Wir gewähren auf unsere Geräte bis zu 5 Jahre Garantie auf die elektrischen und elektronischen Teile und 10 Jahre auf das Material gegen Korrosion. Die zu lackierenden Geräte werden mit einem speziellen ultra-resistenten Polyester-Pulverlack behandelt. Die innovativen HCT-Oberflächen (Hard Coating Treatment) der neuen Kollektion: Inox Graphite - Inox Bronze - Inox Natural garantieren eine hohe Oberflächenbeständigkeit gegen Korrosion und Witterungseinflüsse und schützen die Produkte vor Abdrücken und Flecken.

Art Direction  
Alessandro Zambelli

Graphic Design  
Andrea Bianchi

Copywriting  
Irene Franzoni

Photography  
Chiara Cadeddu  
Marco Moretti  
Carlo Bonazza

Still life images  
Mattia Barozzi

Acknowledgements  
Studio Architrend  
Arch. Roberto Marchini  
CG+TM architetti  
Ghirardi Marmi  
Paghera  
PR.I.MA.

Research & development  
Massimiliano Ferrari

STRAL- Palazzoli S.p.a  
Via F. Palazzoli, 31  
25128 Brescia (BS), Italia

T +39 03020151  
F +39 032015258  
vendite@stral.it  
marketing@stral.it  
stral.it

**STRAL** is a brand of **Palazzoli**  
GROUP

© STRAL- Palazzoli Group, 2021

Tutti i diritti sono riservati. La società si riserva il diritto di apportare modifiche ai prodotti rappresentati senza necessita di preavviso. Condizioni generali di vendita, uso e garanzia sono pubblicate in allegato ai listini in vigore.

All right reserved. The company reserves the right to make changes to the products shown in the catalogue with no prior notice needed. General sales terms, conditions of use and guarantee terms and conditions are published as attachments to the effective price lists. We invite our esteemed customers to look over them.

AND THE  
LAND-  
SCAPE.